

# HL 50A

## TECHNICAL DATA

<b>U</b>	Voltage range:	200-600 V <sub>AC rms</sub>
<b>U<sub>Prüf</sub></b>	Test bench:	800 V <sub>AC</sub>
<b>a<sub>Max</sub></b>	Max. acceleration:	40 m/s <sup>2</sup>
<b>v<sub>Max</sub></b>	Max. speed:	4 m/s
<b>F<sub>N mot</sub></b>	Nominal force:	65 N
<b>F<sub>P mot</sub></b>	Peak force:	180 N
<b>I<sub>N</sub></b>	Nominal current:	2.4 A
<b>I<sub>P</sub></b>	Peak current:	6 A
<b>s<sub>Max</sub></b>	Max. stroke:	150-400 mm
<b>s<sub>red</sub></b>	Reduced stroke with brake:	49 mm
	Repeat accuracy:	0.005 mm
<b>m<sub>rec</sub></b>	Max. recommended load:	4 kg
<b>m<sub>gui 0</sub></b>	Mass of the guide rail with 0 mm stroke:	0.7 kg
<b>m<sub>gui 100</sub></b>	Mass of the guide rail per 100 mm stroke:	0.3 kg
<b>m<sub>carr</sub></b>	Mass of the carriage with motor:	2.1 kg
<b>m<sub>carr FI</sub></b>	Mass of the carriage with motor and flange:	2.2 kg
<b>m<sub>br</sub></b>	Mass of the brake:	0.4 kg
<b>F<sub>Br</sub></b>	Brake force:	145/250 N
<b>p<sub>Br</sub></b>	Opening pressure:	4/6 bar

## LOAD DATA (static)

<b>M<sub>X stat</sub></b>	Max. static moment about the X-axis:	200 Nm
<b>M<sub>Y stat</sub></b>	Max. static moment about the Y-axis:	50 Nm
<b>M<sub>Z stat</sub></b>	Max. static moment about the Z-axis:	300 N
<b>F<sub>X stat</sub></b>	Max. static force in the Y-axis:	500 N
<b>F<sub>Z stat</sub></b>	Max. static force in the Z-axis:	200 N

## LOAD DATA (dynamic)

<b>M<sub>X dyn</sub></b>	Max. dynamic moment about the X-axis:	20 Nm
<b>M<sub>Y dyn</sub></b>	Max. dynamic moment about the Y-axis:	10 Nm
<b>M<sub>Z dyn</sub></b>	Max. dynamic moment about the Z-axis:	30 Nm
<b>F<sub>X dyn</sub></b>	Max. dynamic force in the X-axis:	90 N
<b>F<sub>Z dyn</sub></b>	Max. dynamic force in the Z-axis:	60 N

## ENCODER

Balluff	sin/cos
Balluff	BISS
Balluff	SSI

## LOAD DATA



## TIMING DIAGRAM

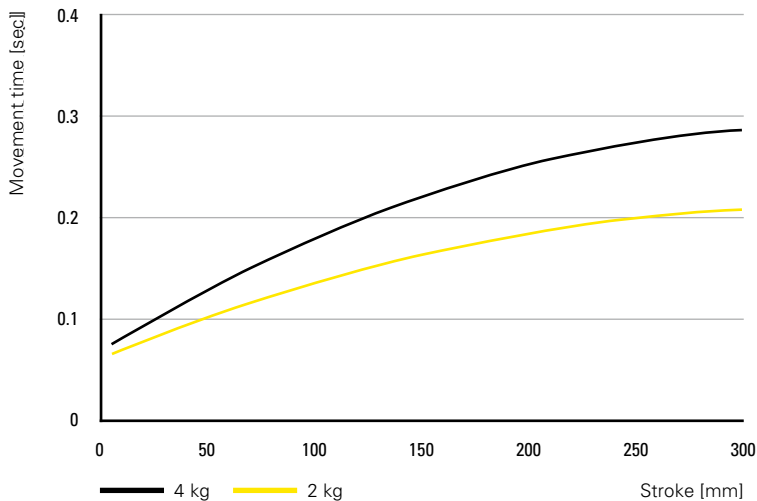

Stroke without brake in mm	Stroke with 1 brake in mm	Dimension L in mm	Dimension A in mm
150 *	100	312	420
200	150	361	469
250	200	410	518
300 *	250	462	570

\* Standard stroke

DIMENSIONS

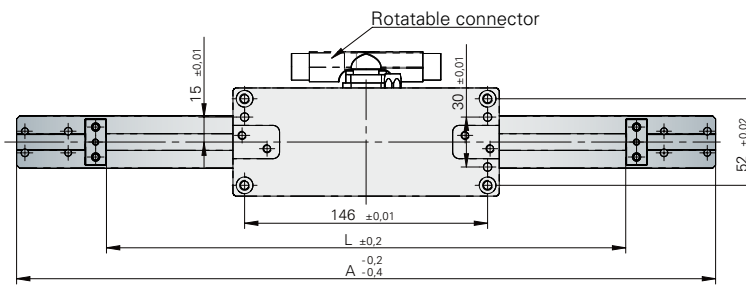
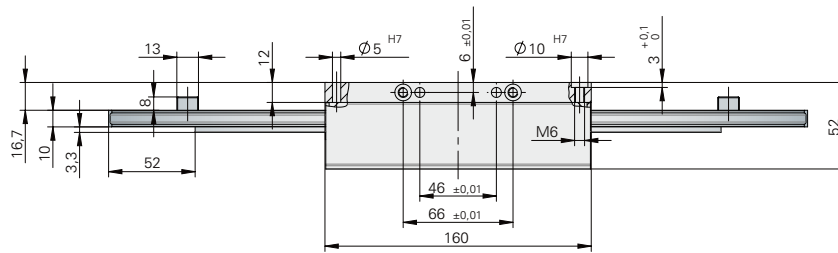
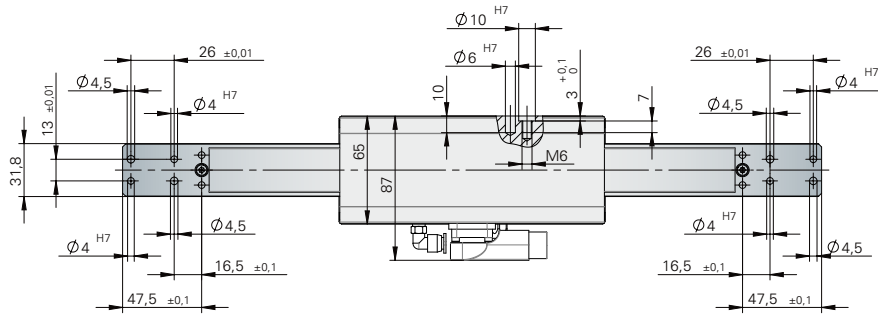

Optionally with holding brake

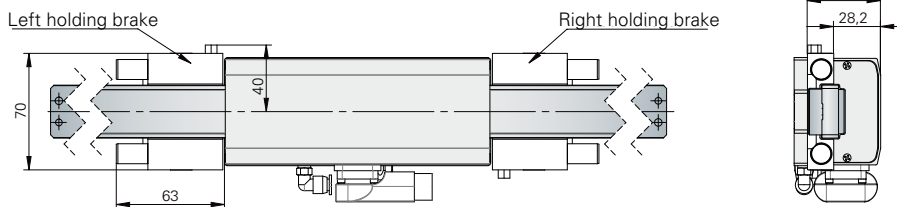

Optionally with wide flange

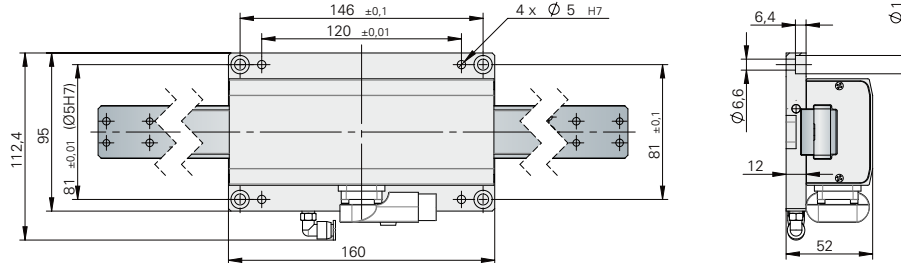

# HL 100A

## TECHNICAL DATA

<b>U</b>	Voltage range:	200-600 V <sub>AC rms</sub>
<b>U<sub>Prüf</sub></b>	Test bench:	800 V <sub>AC</sub>
<b>a<sub>Max</sub></b>	Max. acceleration:	40 m/s <sup>2</sup>
<b>v<sub>Max</sub></b>	Max. speed:	4 m/s
<b>F<sub>N mot</sub></b>	Nominal force:	150 N
<b>F<sub>P mot</sub></b>	Peak force:	380 N
<b>I<sub>N</sub></b>	Nominal current:	3.6 A
<b>I<sub>p</sub></b>	Peak current:	9.5 A
<b>s<sub>Max</sub></b>	Max. stroke:	150-530 mm
<b>s<sub>red</sub></b>	Reduced stroke with brake:	40 mm
	Repeat accuracy:	0.005 mm
<b>m<sub>rec</sub></b>	Max. recommended load:	8 kg
<b>m<sub>gui 0</sub></b>	Mass of the guide rail with 0 mm stroke:	1.8 kg
<b>m<sub>gui 100</sub></b>	Mass of the guide rail per 100 mm stroke:	0.6 kg
<b>m<sub>carr</sub></b>	Mass of the carriage with motor:	3.6 kg
<b>m<sub>carr Fl</sub></b>	Mass of the carriage with motor and flange:	4 kg
<b>m<sub>br</sub></b>	Mass of the brake:	0.5 kg
<b>F<sub>Br</sub></b>	Brake force:	350 N
<b>p<sub>Br</sub></b>	Opening pressure:	6 bar

## LOAD DATA (static)

<b>M<sub>X stat</sub></b>	Max. static moment about the X-axis:	350 Nm
<b>M<sub>Y stat</sub></b>	Max. static moment about the Y-axis:	100 Nm
<b>M<sub>Z stat</sub></b>	Max. static moment about the Z-axis:	500 Nm
<b>F<sub>X stat</sub></b>	Max. static force in the Y-axis:	800 N
<b>F<sub>Z stat</sub></b>	Max. static force in the Z-axis:	400 N

## LOAD DATA (dynamic)

<b>M<sub>X dyn</sub></b>	Max. dynamic moment about the X-axis:	35 Nm
<b>M<sub>Y dyn</sub></b>	Max. dynamic moment about the Y-axis:	15 Nm
<b>M<sub>Z dyn</sub></b>	Max. dynamic moment about the Z-axis:	40 Nm
<b>F<sub>X dyn</sub></b>	Max. dynamic force in the X-axis:	150 N
<b>F<sub>Z dyn</sub></b>	Max. dynamic force in the Z-axis:	100 N

## ENCODER

Balluff	sin/cos
Balluff	BISS
Balluff	SSI

## LOAD DATA

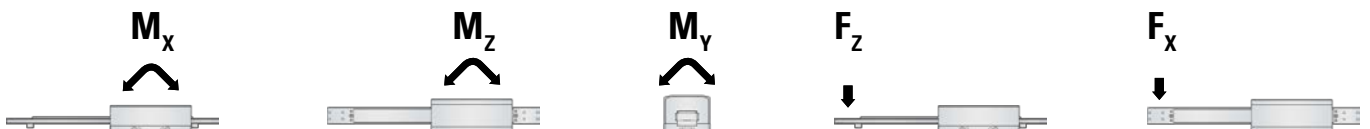

## TIMING DIAGRAM

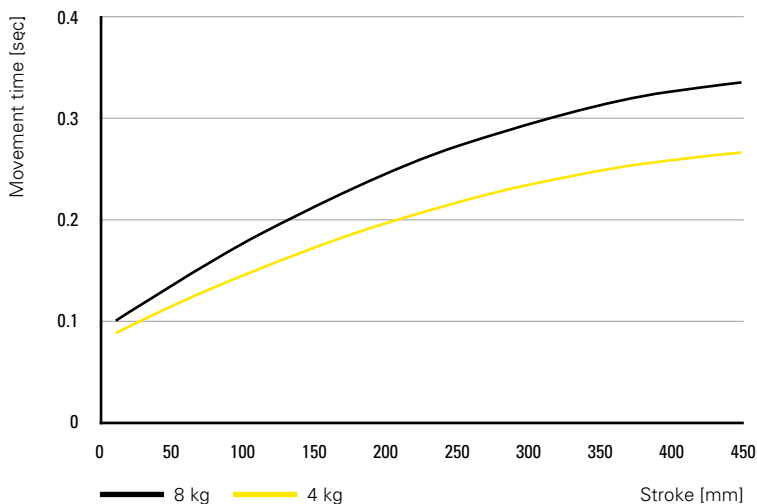

Stroke without brake in mm	Stroke with 1 brake in mm	Dimension L in mm	Dimension A in mm
150 *	110	326	453
190	150	365.5	492.5
230	190	405	532
300 *	260	476	603
340	300	515.5	642.5
380	340	555	682
450 *	410	626	753

\* Standard stroke

DIMENSIONS

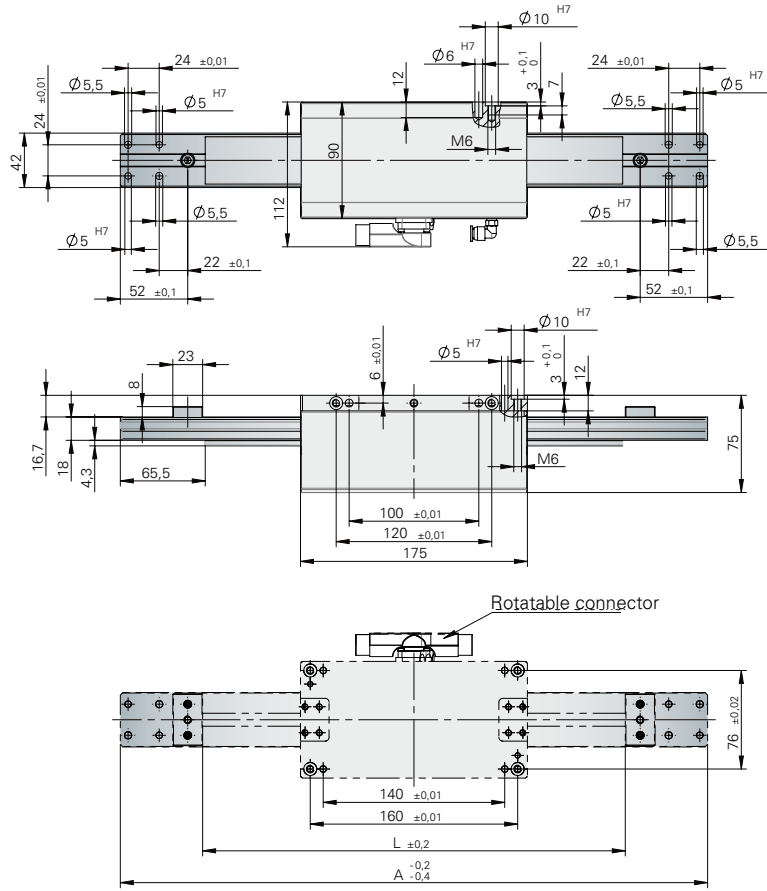

Optionally with holding brake

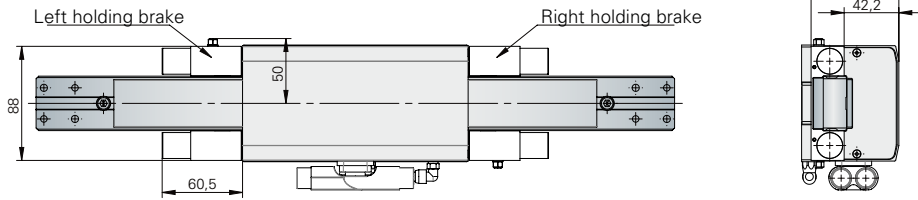

Optionally with wide flange

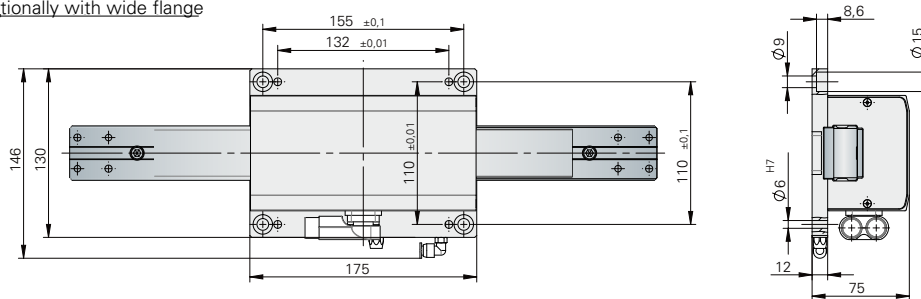

# HG/HN

LINEAR MOTOR AXES | HG/HN LINEAR AXIS

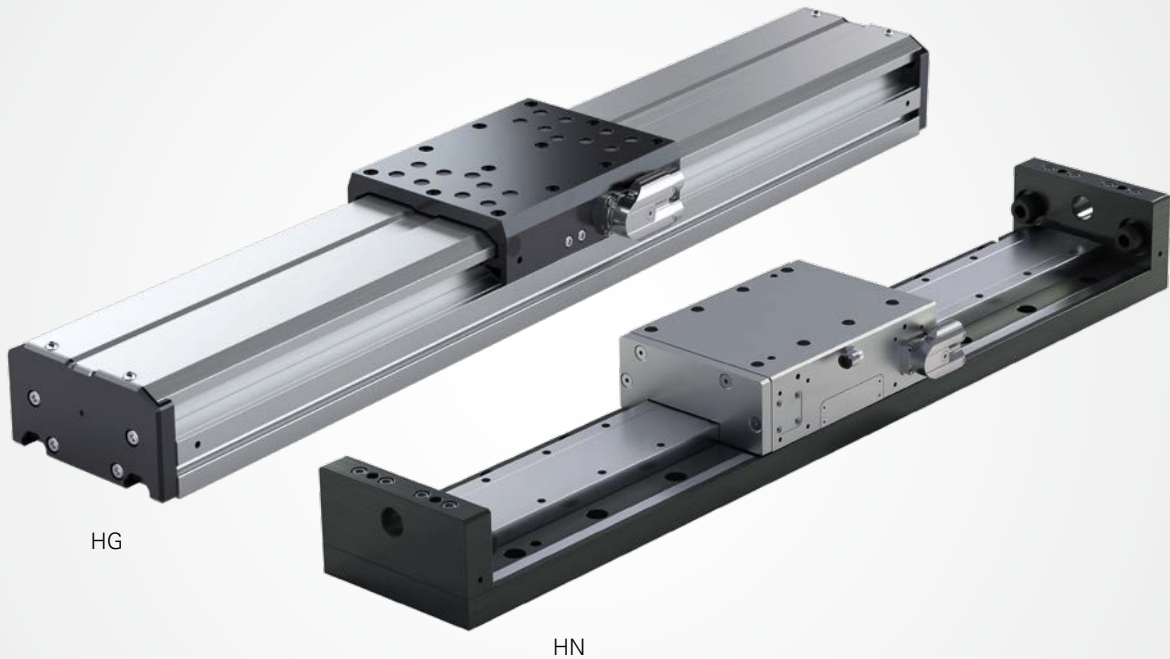

## HG/HN LINEAR MOTOR AXES

### TWO SIZES

The two sizes of the HG axis: HG 25 with a peak force of 180 N, and HG 12 with a peak force of 110 N

### FREELY AND INTUITIVELY PROGRAMMABLE

W.A.S. 2 – WEISS Application Software: secure and fast commissioning with free-of-charge user software.



OKU relies on the perfect combination of HN and HL axes for its ball bearing assembly cell. User-programmable linear motor axes are the ideal choice for extremely fast process movements and strict requirements in terms of both dynamic performance and precision.



The latest in uncompromising, highly dynamic drive technology for your basic axis. Highly integrated and ready for installation. Compact and precise ball-type linear guides and an absolute measuring system are just as much a part of the concept as the automatic lubrication. The HN version is available in many different sizes – with a robust steel body or lightweight aluminium body. The aluminium profile-based HG axes can also be used in areas in which cost factors have typically made conventional drives the standard choice in the past: the most advanced linear technology at extremely attractive conditions. Both versions impress with their smooth movements and maximum dynamics.

---

## ADVANTAGES

- Freely positionable
- Extremely high dynamic performance thanks to direct drive
- Low maintenance costs
- Low energy costs
- Compact design
- Convincing price-quality ratio (particularly in the case of HG axes)
- HN axes with high power density available in many different sizes
- HG axes with covered guide profile with standard attachment options

---

## GENERAL INFORMATION

- The HG model range comes with lifetime lubrication, making maintenance intervals a thing of the past.
- All motors are equipped with overtemperature protection (PTC)
- The installation location of the linear axes can be freely chosen

---

## OPTIONS

- The HN linear axes can be equipped with manual or automatic lubrication
- Multiple carriages on a single axis
- Absolute measuring systems
- Functional safety (secure encoder attachment)