

**CHARACTERISTICS**

The **MTJZ** series contains Z-axis Linear Units with toothed belt drive, integrated Ball rail system and compact dimensions. This Linear Units provide high performance features such as, high speed, good accuracy and repeatability by vertical applications.

They can easily be combined to multi-axis systems.

Excellent price-/performance ratio and quick delivery time are ensured.

The compact, precision-extruded aluminum Profile from 6063 AL with integrated Zero-backlash Ball rail guide system, allows high load capacities and optimal cycles for the movement of larger masses at high speed.

In the linear units MTJZ is used a pre-tensioned steel reinforced AT polyurethane timing toothed belt. In conjunction with a Zero-backlash drive pulley high moments with alternating loads with good positioning accuracy, low wear and low noise can be realized.

The in the Profile slot driving Polyurethane timing belt protects all the parts in the Profile from dust and other contaminations

The aluminum Profile includes T-slots for attaching sensors and switches. Also, a Reed switch can be used here.

The drive block provides the possibility to attach a Motor or Gearbox housing and additional accessories on it.

Central lubrication port on the drive block allows easy re-lubrication of the Ball rail guide.

For the linear units MTJZ various adaptation options, for attaching (or redirecting), for Motors or Gearboxes are available.

**i** Multi drive blocks, which travel independently of each other, can be applied.

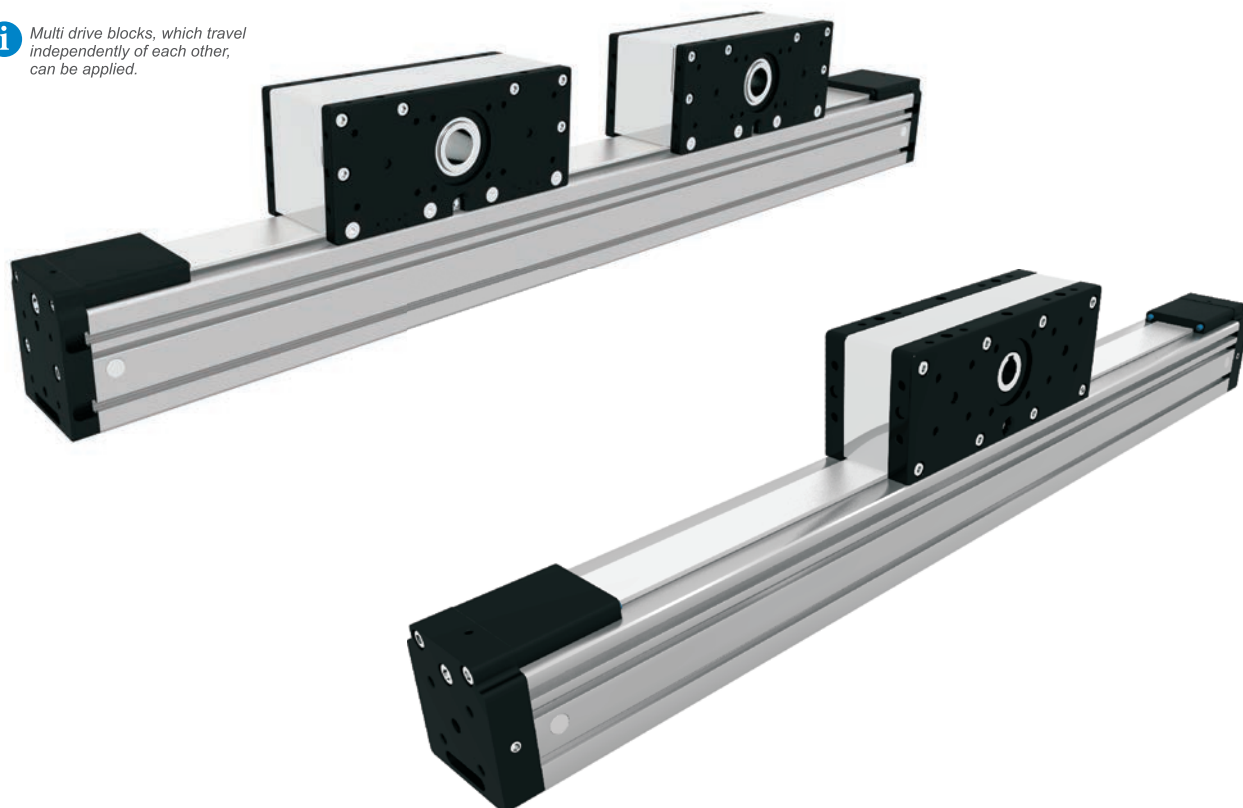

**i** The aluminium profiles are manufactured according to the medium EN 12020-2 standard

*Straightness = 0,35 mm/m; Max. torsion = 0,35 mm/m; Angular torsion = 0,2 mm/40 mm; Parallelism = 0,2 mm*

STRUCTURAL DESIGN

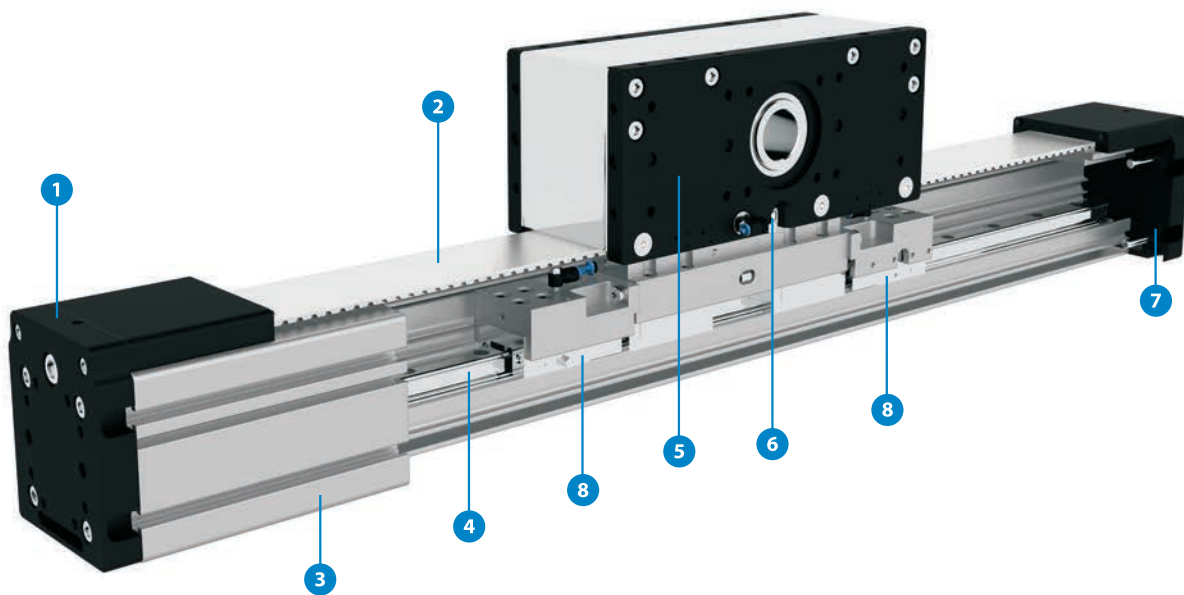

- 1 - Tension End with integrated belt tensionin system
- 2 - AT polyurethane toothed belt with steel tension cords
- 3 - Aluminium profile-Hard anodized
- 4 - Linear Ball Guideway
- 5 - Drive block with pulley, Motor flange; with built in Magnets
- 6 - Central lubrication port; both sides
- 7 - Tension End with integrated belt tensioning system
- 8 - Clamping and braking element for linear guideway

**MTJZ** - **65** - **1000** - **1** - **0** - **1**

**Series :** \_\_\_\_\_

**MTJZ**

**Size :** \_\_\_\_\_

**40**

**65**

**80**

**110**

**Absolute Stroke (mm) :** \_\_\_\_\_

(Absolute stroke = Effective stroke + 2 x Safety stroke)

**Type of drive pulley :** \_\_\_\_\_

**0 :** Pulley with through hole

**1 :** Pulley with journal

**10 :** Pulley with journal (without Keyway)

**2 :** Pulley with journal on both sides

**20 :** Pulley with journal on both sides (without Keyway)

**!** *MTJZ 110 only available with drive pulley with through hole*

**Clamping element :** \_\_\_\_\_

**0 :** Without

**1 :** With (available only for MTJZ 110)

**!** *Only as emergency break!*

**Number of drive blocks :** \_\_\_\_\_

The stated number specifies the number of drive blocks on one Linear unit

**TECHNICAL DATA**

**General technical data**

Linear Unit	Drive block length Lv [ mm ]	Dynamic load capacity C [ N ]	Dynamic moment			Mass of drive block [ kg ]	Maximum Repeatability [ mm ]	Max. length <sup>2</sup> (Version 1) Lmax [ mm ]	Max. length <sup>2</sup> (Version 2) Lmax [ mm ]	Max. Stroke		Min. Stroke [ mm ]
			Mx [ Nm ]	My [ Nm ]	Mz [ Nm ]					<sup>2</sup> (Ver. 1) [ mm ]	<sup>2</sup> (Ver. 2) [ mm ]	
MTJZ 40	120	4610	28	120	120	0,95	±0,08	1000	3000	792	2792	25

<sup>1</sup> For minimum stroke below the stated value in the table above please contact us.

<sup>3</sup> For lengths / stroke over the stated value in the table above please contact us.  
Values for max. stroke are not valid for multi drive block  
(equation of defining the linear unit length for particular size of the linear unit needs to be used).

Linear Unit	Max. permissible loads				
	Forces		Moments		
	Fpy [ N ]	Fpz [ N ]	Mpx [ Nm ]	Mpy [ Nm ]	Mpz [ Nm ]
MTJZ 40	2320	1510	14	40	62

**i Recommended values of loads**

All the data of dynamic moments and load capacities stated in the upper table are theoretical without considering any safety factor. The safety factor depends on the application and its requested safety. We recommend a minimum safety factor (fs =5.0)

**Modulus of elasticity:**  $E = 70000 \text{ N / mm}^2$

Operating conditions	
Operating temp.	0°C ~ +60°C
Duty cycle	100%

For operating temperature out of the presented range, please contact us.

**<sup>2</sup> Mounting versions**

**Version 1:** Mounting by the drive block, profile travels

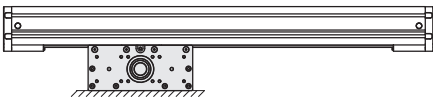

**Version 2:** Mounting by the profile, drive block travels

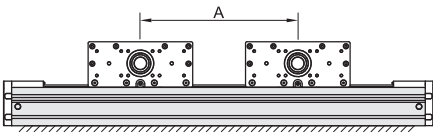

Multi drive blocks, which travel independently of each other, can be applied.  
For ordering code please contact us.

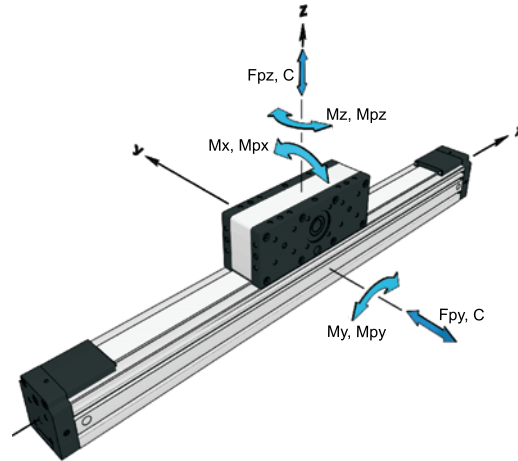

**Drive and belt data**

Linear Unit	** Max. travel speed [ m / s ]	Max. drive torque [ Nm ]	* No load torque [ Nm ]	Puley drive ratio [ mm / rev ]	Pulley diameter [ mm ]	Belt type	Belt width [ mm ]	Max. force transmitted by belt [ N ]	Specific spring constant Cspec [ N ]	** Max. acceleration [ m/s <sup>2</sup> ]
MTJZ 40	5	3,6	0,2	99	31,51	AT3	20	230	225000	70

\*The stated values are for strokes up to 500mm. No Load Torque value increases with stroke elongation.

\*\*For travel speed and acceleration over the stated value in the table above or diagrams please contact us.

**Mass and mass moment of inertia**

Linear Unit	Mass of linear unit [ kg ]	Mass moment of inertia of drive block [ 10 <sup>-4</sup> kg * m <sup>2</sup> ]	Planar moment of inertia	
			Iy [ cm <sup>4</sup> ]	Iz [ cm <sup>4</sup> ]
MTJZ 40	1,7 + 0,0023 * Stroke [ mm ]	2,3 + 0,0058 * Stroke [ mm ]	9,8	11,6

**i** Mass calculation doesn't include mass of motor, reduction gear, switches and clamps.

Deflection of the linear unit

Fixed - fixed mounting

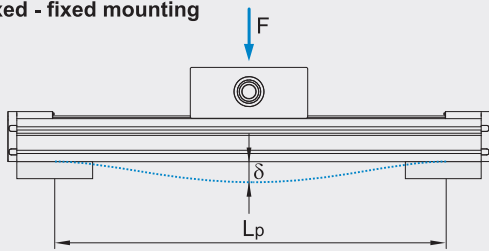

Fixed - free mounting

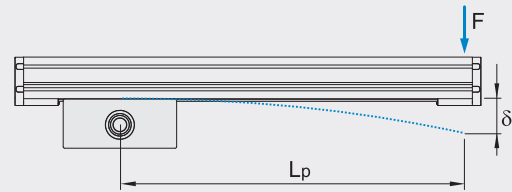

- $\delta$  Maximum deflection of the linear unit [mm]
- $\delta_{max}$  Maximum permissible deflection of the linear unit [mm]
- F Applied force [N]
- $L_p$  Unsupported profile length [mm]

**i** The maximum permissible deflection  $\delta_{max}$  must not be exceeded. In the case that maximum deflection  $\delta$  exceeds the maximum permissible deflection  $\delta_{max}$  additional profile supports are needed.

MTJZ 40

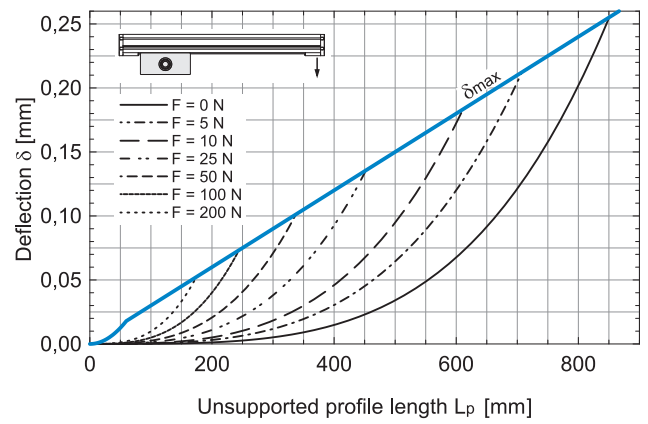
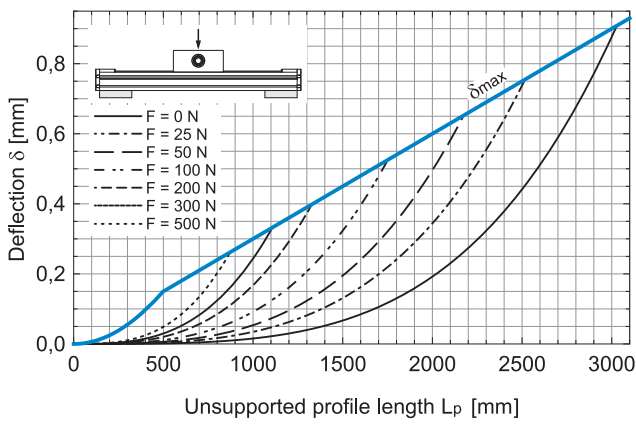



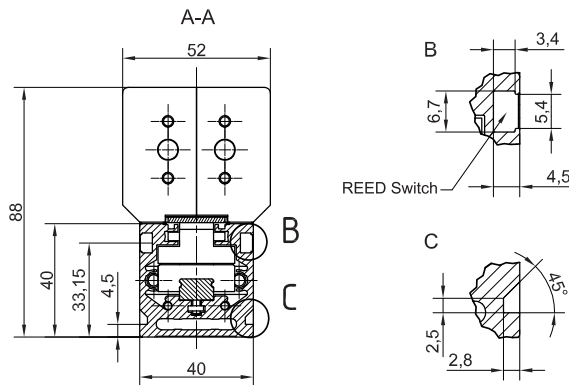
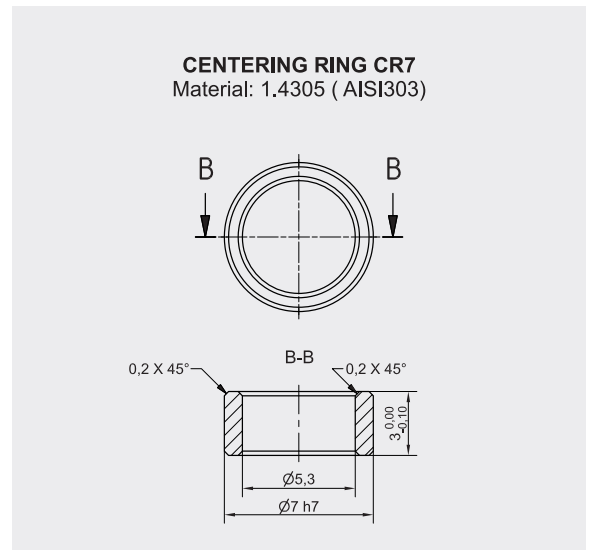
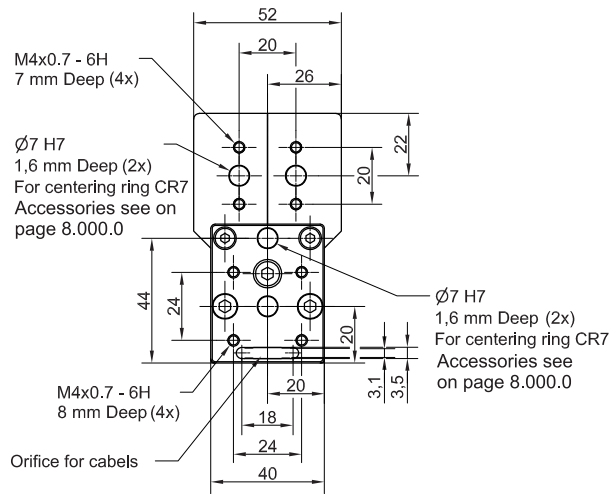

**i** All dimensions in mm; Drawings scales are not equal.

**Defining of the linear unit length**

**L = Effective stroke + 2 × Safety stroke + 208 mm**

**Ltotal = L + 24 mm**

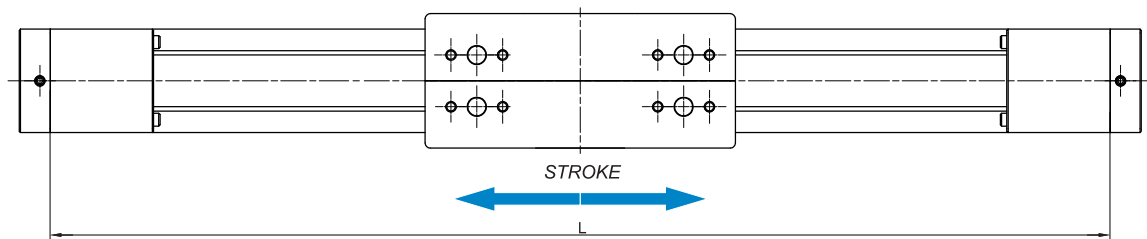

**Multi drive block**

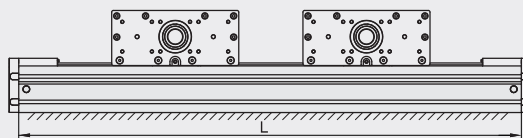

**L = Effective stroke + 2 × Safety stroke + 120 × n<sub>b</sub> + 88 mm**

n<sub>b</sub> - number of drive blocks

**Ltotal = L + 24 mm**

**TECHNICAL DATA**

**General technical data**

Linear Unit	Drive block length Lv [ mm ]	Dynamic load capacity C [ N ]	Dynamic moment			Mass of drive block [ kg ]	Maximum Repeatability [ mm ]	Max. length <sup>2</sup> (Version 1) Lmax [ mm ]	Max. length <sup>2</sup> (Version 2) Lmax [ mm ]	Max. Stroke		Min. Stroke [ mm ]
			Mx [ Nm ]	My [ Nm ]	Mz [ Nm ]					<sup>2</sup> (Ver. 1) [ mm ]	<sup>2</sup> (Ver. 2) [ mm ]	
MTJZ 65	200	19800	158	1025	1025	3,2	±0,08	1200	6000	880	5680	40

<sup>1</sup> For minimum stroke below the stated value in the table above please contact us.

<sup>3</sup> For lengths / stroke over the stated value in the table above please contact us.  
Values for max. stroke are not valid for multi drive block  
(equation of defining the linear unit length for particular size of the linear unit needs to be used).

Linear Unit	Max. permissible loads				
	Forces		Moments		
	Fpy [ N ]	Fpz [ N ]	Mpx [ Nm ]	Mpy [ Nm ]	Mpz [ Nm ]
MTJZ 65	6540	5870	60	305	340

**i Recommended values of loads**

All the data of dynamic moments and load capacities stated in the upper table are theoretical without considering any safety factor. The safety factor depends on the application and its requested safety. We recommend a minimum safety factor (fs =5.0)

**Modulus of elasticity:**  $E = 70000 \text{ N / mm}^2$

**Operating conditions**

Operating temp.	0°C ~ +60°C
Duty cycle	100%

For operating temperature out of the presented range, please contact us.

**<sup>2</sup> Mounting versions**

**Version 1:** Mounting by the drive block, profile travels

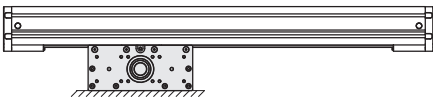

**Version 2:** Mounting by the profile, drive block travels

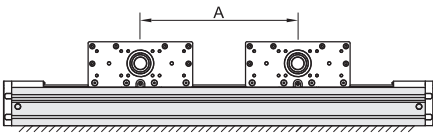

Multi drive blocks, which travel independently of each other, can be applied.  
For ordering code please contact us.

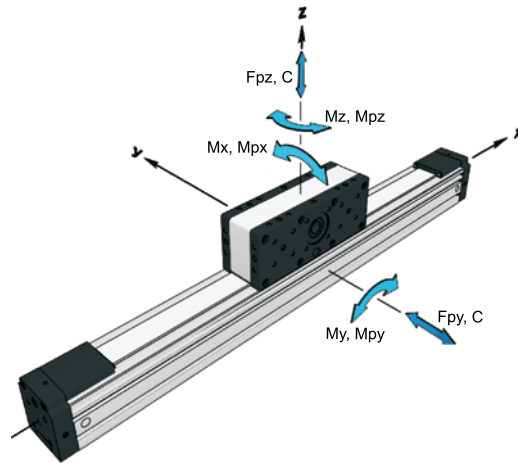

**Drive and belt data**

Linear Unit	** Max. travel speed [ m / s ]	Max. drive torque [ Nm ]	* No load torque [ Nm ]	Pulley drive ratio [ mm / rev ]	Pulley diameter [ mm ]	Belt type	Belt width [ mm ]	Max. force transmitted by belt [ N ]	Specific spring constant Cspec [ N ]	** Max. acceleration [ m/s <sup>2</sup> ]
MTJZ 65	5	13,1	0,9	165	52,52	AT5	32	500	600000	70

\*The stated values are for strokes up to 500mm. No Load Torque value increases with stroke elongation.

\*\*For travel speed and acceleration over the stated value in the table above or diagrams please contact us.

**Mass and mass moment of inertia**

Linear Unit	Mass of linear unit [ kg ]	Mass moment of inertia of drive block [ 10 <sup>-4</sup> kg * m <sup>2</sup> ]	Planar moment of inertia	
			Iy [ cm <sup>4</sup> ]	Iz [ cm <sup>4</sup> ]
MTJZ 65	5,7 + 0,0054 * Hub [ mm ]	18,9 + 0,0374 * Hub [ mm ]	59,7	74,4

**i** Mass calculation doesn't include mass of motor, reduction gear, switches and clamps.



Deflection of the linear unit

Fixed - fixed mounting

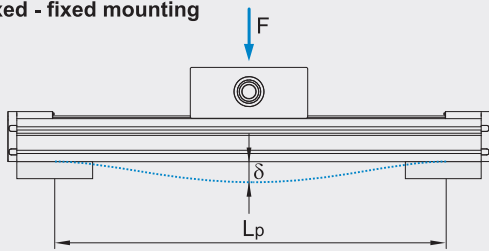

Fixed - free mounting

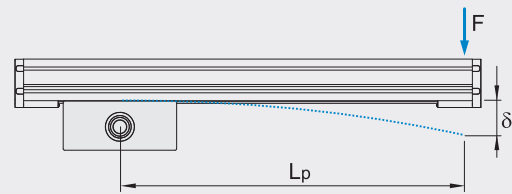

- $\delta$  Maximum deflection of the linear unit [mm]
- $\delta_{max}$  Maximum permissible deflection of the linear unit [mm]
- $F$  Applied force [N]
- $L_p$  Unsupported profile length [mm]

**i** The maximum permissible deflection  $\delta_{max}$  must not be exceeded. In the case that maximum deflection  $\delta$  exceeds the maximum permissible deflection  $\delta_{max}$  additional profile supports are needed.

MTJZ 65

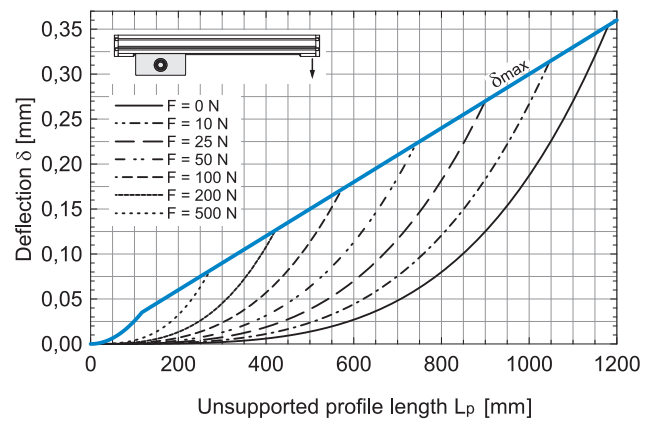
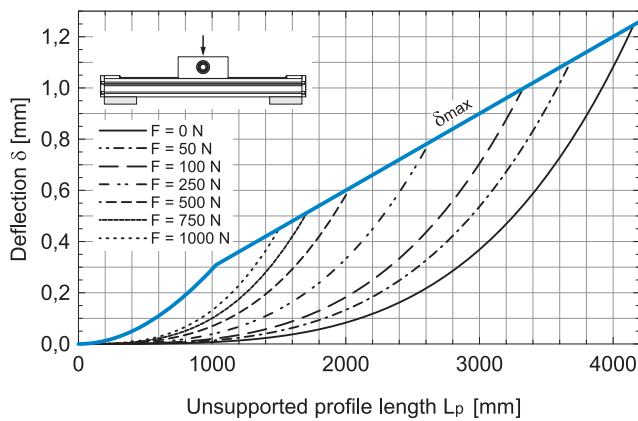



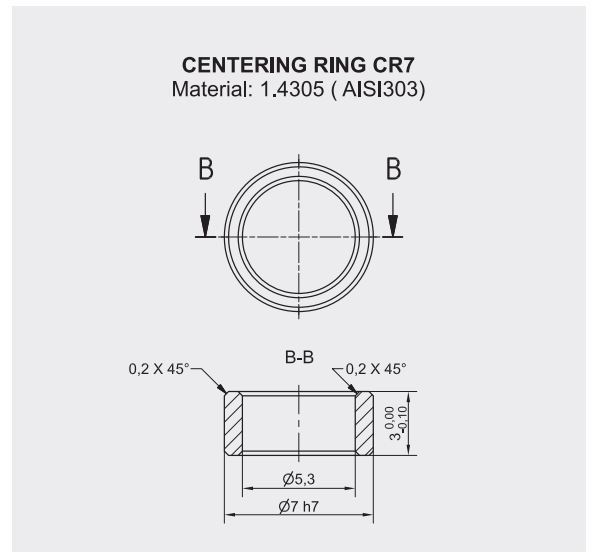
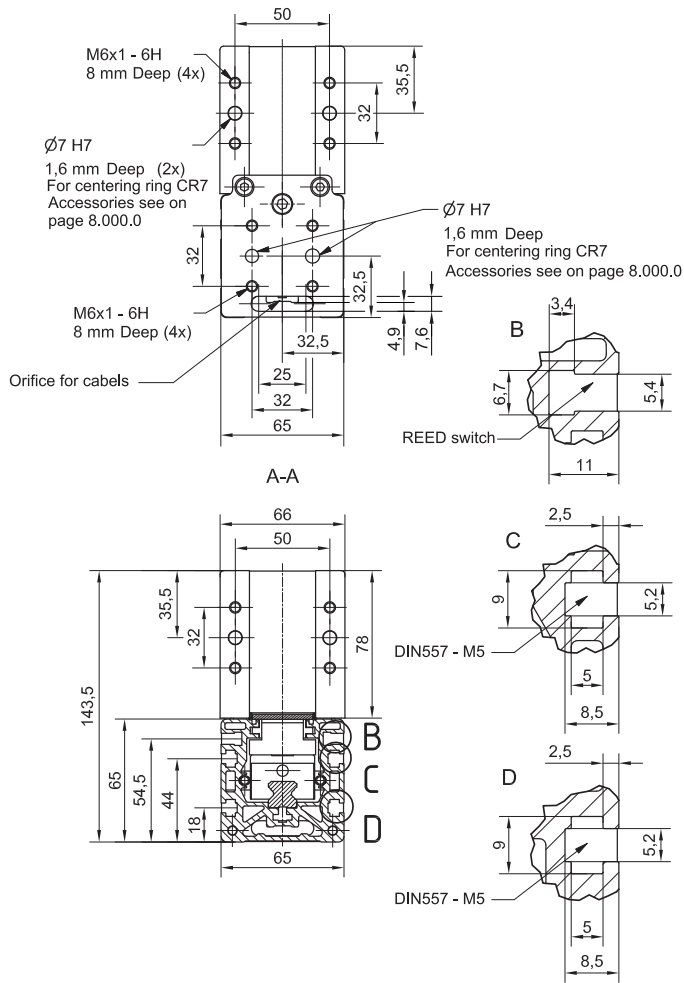

**i** All dimensions in mm; Drawings scales are not equal.

Defining of the linear unit length

**L = Effective stroke + 2 × Safety stroke + 320 mm**

**Ltotal = L + 40 mm**

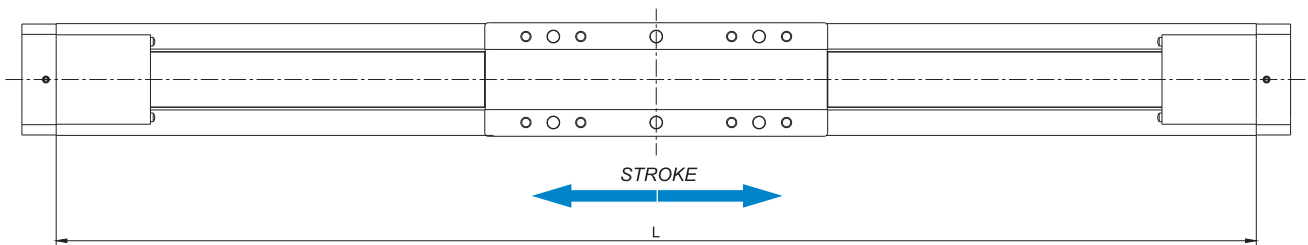

**Multi drive block**

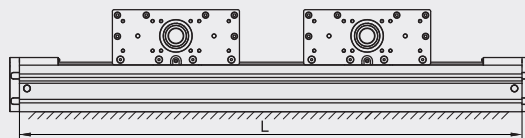

**L = Effective stroke + 2 × Safety stroke + 200 × n<sub>b</sub> + 120 mm**

n<sub>b</sub> - number of drive blocks

**Ltotal = L + 40 mm**

**TECHNICAL DATA**

**General technical data**

Linear Unit	Drive block length Lv [ mm ]	Dynamic load capacity C [ N ]	Dynamic moment			Mass of drive block [ kg ]	Maximum Repeatability [ mm ]	Max. length <sup>2</sup> (Version 1) Lmax [ mm ]	Max. length <sup>2</sup> (Version 2) Lmax [ mm ]	Max. Stroke		Min. Stroke [ mm ]
			Mx [ Nm ]	My [ Nm ]	Mz [ Nm ]					<sup>2</sup> (Ver. 1) [ mm ]	<sup>2</sup> (Ver. 2) [ mm ]	
MTJZ 80	250	34200	370	2565	2565	4,9	±0,08	1500	6000	1118	5618	55

<sup>1</sup> For minimum stroke below the stated value in the table above please contact us.

<sup>3</sup> For lengths / stroke over the stated value in the table above please contact us.  
Values for max. stroke are not valid for multi drive block  
(equation of defining the linear unit length for particular size of the linear unit needs to be used).

Linear Unit	Max. permissible loads				
	Forces		Moments		
	Fpy [ N ]	Fpz [ N ]	Mpx [ Nm ]	Mpy [ Nm ]	Mpz [ Nm ]
MTJZ 80	8930	7130	150	535	670

**i Recommended values of loads**

All the data of dynamic moments and load capacities stated in the upper table are theoretical without considering any safety factor. The safety factor depends on the application and its requested safety. We recommend a minimum safety factor (fs =5.0)

**Modulus of elasticity:**  $E = 70000 \text{ N / mm}^2$

Operating conditions	
Operating temp.	0°C ~ +60°C
Duty cycle	100%

For operating temperature out of the presented range, please contact us.

**2 Mounting versions**

**Version 1:** Mounting by the drive block, profile travels

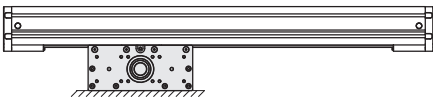

**Version 2:** Mounting by the profile, drive block travels

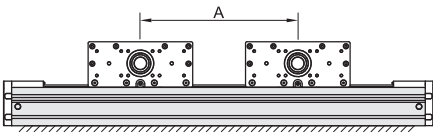

Multi drive blocks, which travel independently of each other, can be applied.  
For ordering code please contact us.

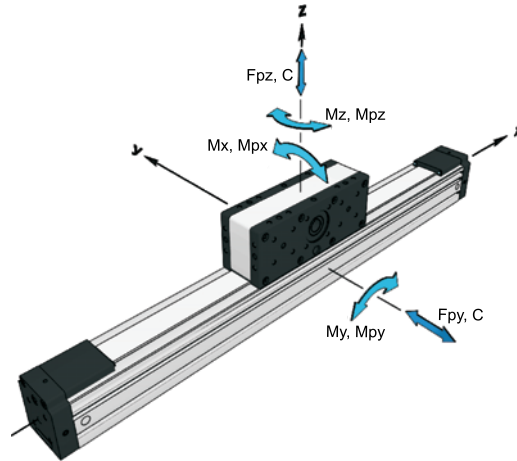

**Drive and belt data**

Linear Unit	** Max. travel speed [ m / s ]	Max. drive torque [ Nm ]	* No load torque [ Nm ]	Puley drive ratio [ mm / rev ]	Pulley diameter [ mm ]	Belt type	Belt width [ mm ]	Max. force transmitted by belt [ N ]	Specific spring constant Cspec [ N ]	** Max. acceleration [ m/s <sup>2</sup> ]
MTJZ 80	5	29,4	1,4	210	66,84	AT5	50	880	960000	70

\* The stated values are for strokes up to 500mm. No Load Torque value increases with stroke elongation.

\*\* For travel speed and acceleration over the stated value in the table above or diagrams please contact us.

**Mass and mass moment of inertia**

Linear Unit	Mass of linear unit [ kg ]	Mass moment of inertia of drive block [ 10 <sup>-4</sup> kg * m <sup>2</sup> ]	Planar moment of inertia	
			Iy [ cm <sup>4</sup> ]	Iz [ cm <sup>4</sup> ]
MTJZ 80	9,7 + 0,0083 * Stroke [ mm ]	60,5 + 0,0922 * Stroke [ mm ]	129,1	173,4

**i** Mass calculation doesn't include mass of motor, reduction gear, switches and clamps.

Deflection of the linear unit

Fixed - fixed mounting

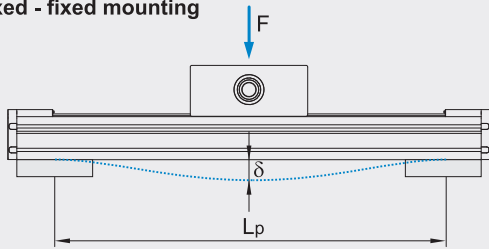

Fixed - free mounting

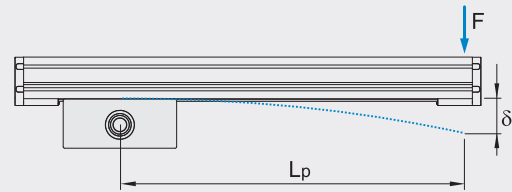

- $\delta$  Maximum deflection of the linear unit [mm]
- $\delta_{max}$  Maximum permissible deflection of the linear unit [mm]
- F Applied force [N]
- $L_p$  Unsupported profile length [mm]



The maximum permissible deflection  $\delta_{max}$  must not be exceeded. In the case that maximum deflection  $\delta$  exceeds the maximum permissible deflection  $\delta_{max}$  additional profile supports are needed.

MTJZ 80

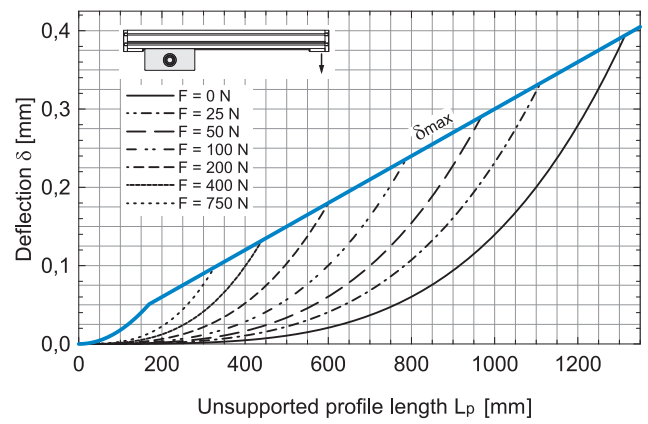
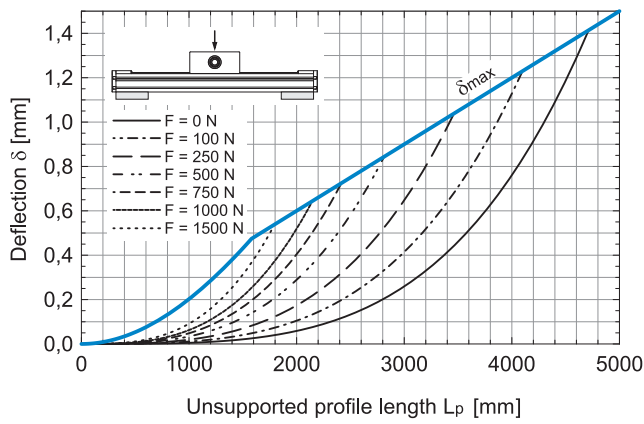



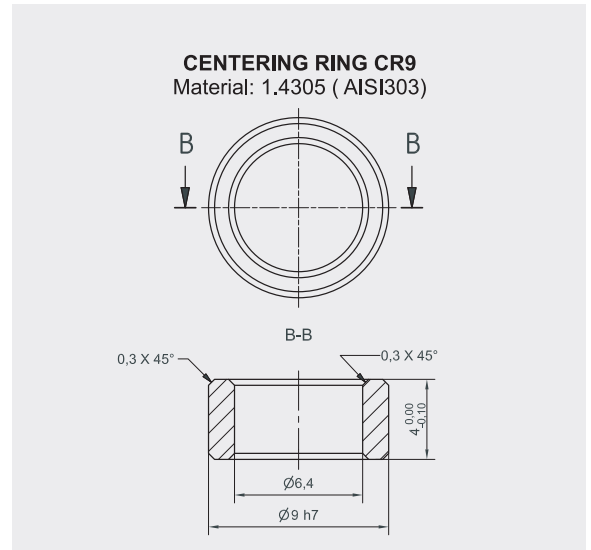
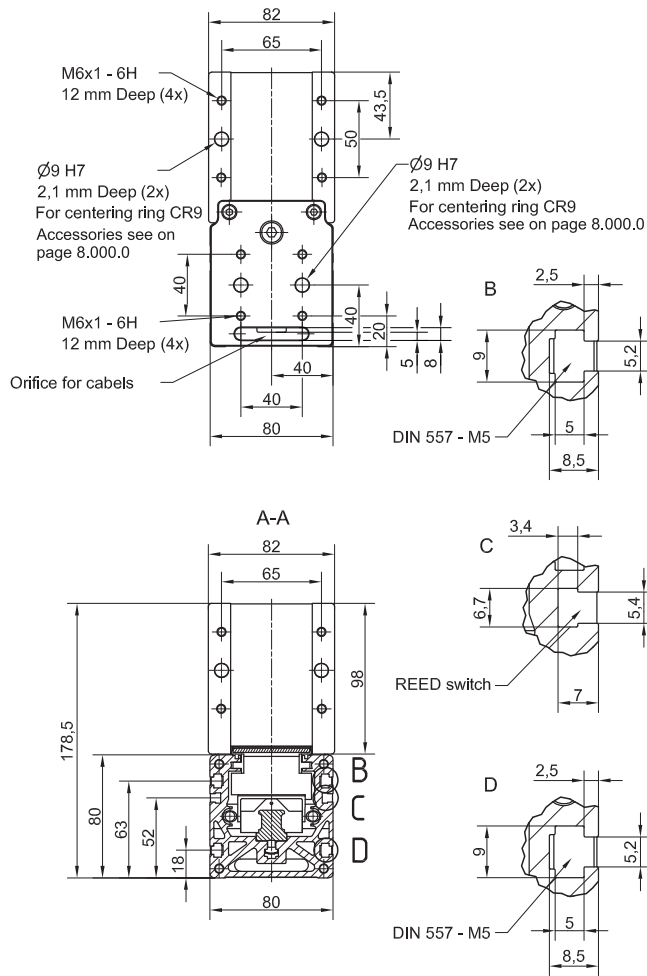

**i** All dimensions in mm; Drawings scales are not equal.

**Defining of the linear unit length**

**L = Effective stroke + 2 × Safety stroke + 382 mm**

**Ltotal = L + 44 mm**

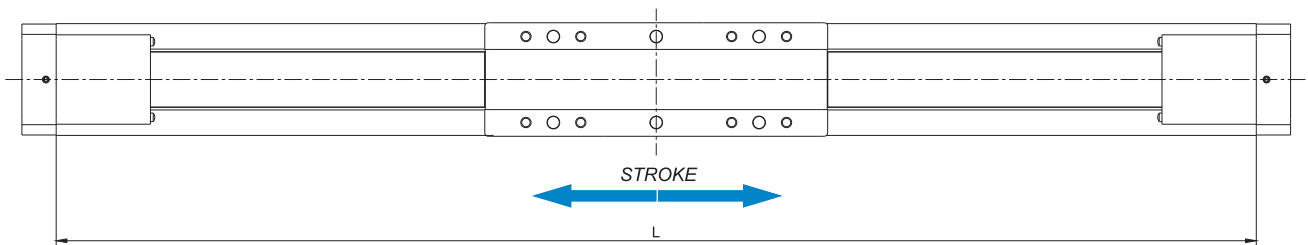

**Multi drive block**

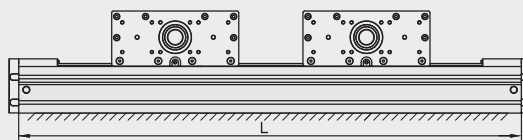

**L = Effective stroke + 2 × Safety stroke + 250 × n<sub>b</sub> + 132 mm**

n<sub>b</sub> - number of drive blocks

**Ltotal = L + 44 mm**

## TECHNICAL DATA

### General technical data

Linear Unit	Drive block length Lv [ mm ]	Dynamic load capacity C [ N ]	Dynamic moment			Mass of drive block [ kg ]	Maximum Repeatability [ mm ]	Max. length <sup>2</sup> (Version 1) Lmax [ mm ]	Max. length <sup>2</sup> (Version 2) Lmax [ mm ]	Max. Stroke		Min. Stroke [ mm ]
			Mx [ Nm ]	My [ Nm ]	Mz [ Nm ]					<sup>2</sup> (Ver. 1) [ mm ]	<sup>2</sup> (Ver. 2) [ mm ]	
MTJZ 110	300	49600	630	3470	3470	11,3	±0,08	1800	6000	1304	5504	65

<sup>1</sup> For minimum stroke below the stated value in the table above please contact us.

<sup>3</sup> For lengths / stroke over the stated value in the table above please contact us.  
Values for max. stroke are not valid for multi drive block  
(equation of defining the linear unit length for particular size of the linear unit needs to be used).

Linear Unit	Max. permissible loads				
	Forces		Moments		
	Fpy [ N ]	Fpz [ N ]	Mpx [ Nm ]	Mpy [ Nm ]	Mpz [ Nm ]
MTJZ 110	10000	14290	260	1000	700

### **i** Recommended values of loads

All the data of dynamic moments and load capacities stated in the upper table are theoretical without considering any safety factor. The safety factor depends on the application and its requested safety. We recommend a minimum safety factor (fs = 5.0)

**Modulus of elasticity:**  $E = 70000 \text{ N / mm}^2$

### Operating conditions

Operating temp.	0°C ~ +60°C
Duty cycle	100%

For operating temperature out of the presented range, please contact us.

### <sup>2</sup> Mounting versions

**Version 1:** Mounting by the drive block, profile travels

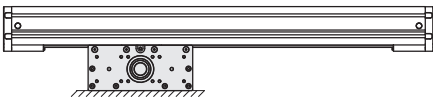

**Version 2:** Mounting by the profile, drive block travels

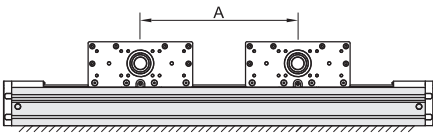

Multi drive blocks, which travel independently of each other, can be applied.  
For ordering code please contact us.

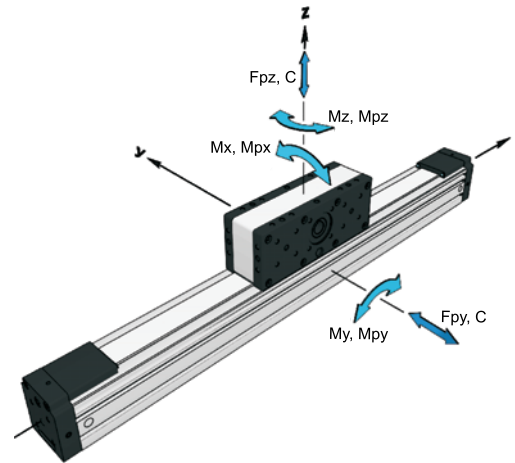

### Drive and belt data

Linear Unit	** Max. travel speed [ m / s ]	Max. drive torque [ Nm ]	* No load torque [ Nm ]	Pulley drive ratio [ mm / rev ]	Pulley diameter [ mm ]	Belt type	Belt width [ mm ]	Max. force transmitted by belt [ N ]	Specific spring constant Cspec [ N ]	** Max. acceleration [ m/s <sup>2</sup> ]
MTJZ 110	5	110,0	2,6	300	95,49	AT10	70	2300	2450000	70

\* The stated values are for strokes up to 500mm. No Load Torque value increases with stroke elongation.

\*\* For travel speed and acceleration over the stated value in the table above or diagrams please contact us.

### Mass and mass moment of inertia

Linear Unit	Mass of linear unit	Mass moment of inertia of drive block	Planar moment of inertia	
	[ kg ]	[ 10 <sup>-4</sup> kg * m <sup>2</sup> ]	Iy [ cm <sup>4</sup> ]	Iz [ cm <sup>4</sup> ]
MTJZ 110	21,7 + 0,0147 * Stroke [ mm ]	273,0 + 0,3358 * Stroke [ mm ]	513,0	620,0

**i** Mass calculation doesn't include mass of motor, reduction gear, switches and clamps.



Deflection of the linear unit

Fixed - fixed mounting

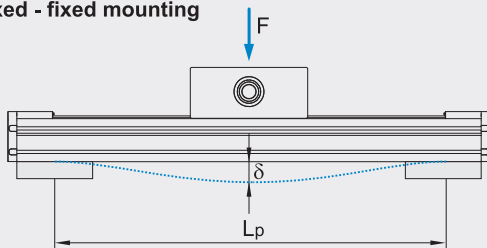

Fixed - free mounting

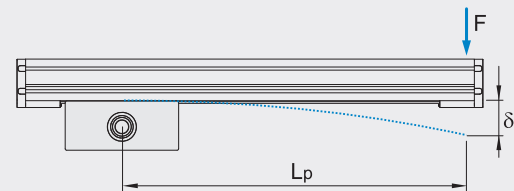

- $\delta$  Maximum deflection of the linear unit [mm]
- $\delta_{max}$  Maximum permissible deflection of the linear unit [mm]
- F Applied force [N]
- $L_p$  Unsupported profile length [mm]



The maximum permissible deflection  $\delta_{max}$  must not be exceeded. In the case that maximum deflection  $\delta$  exceeds the maximum permissible deflection  $\delta_{max}$  additional profile supports are needed.

MTJZ 110

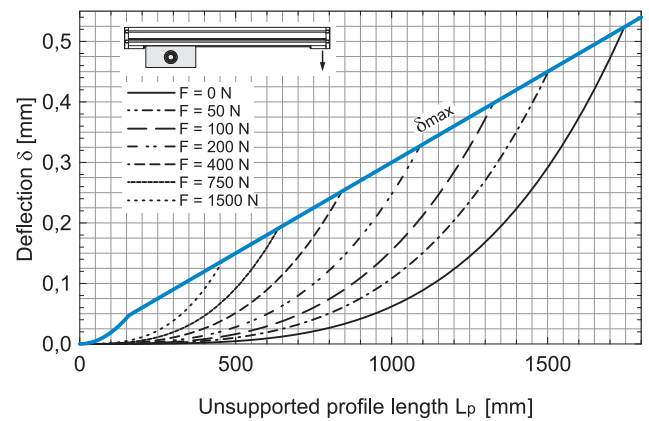
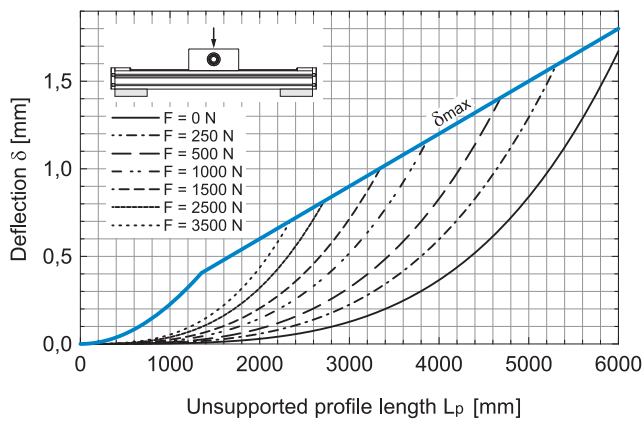

**DIMENSIONS**

**i** Linear Unit doesn't include any safety stroke.  
Absolute stroke = Effective stroke + 2 x Safety stroke

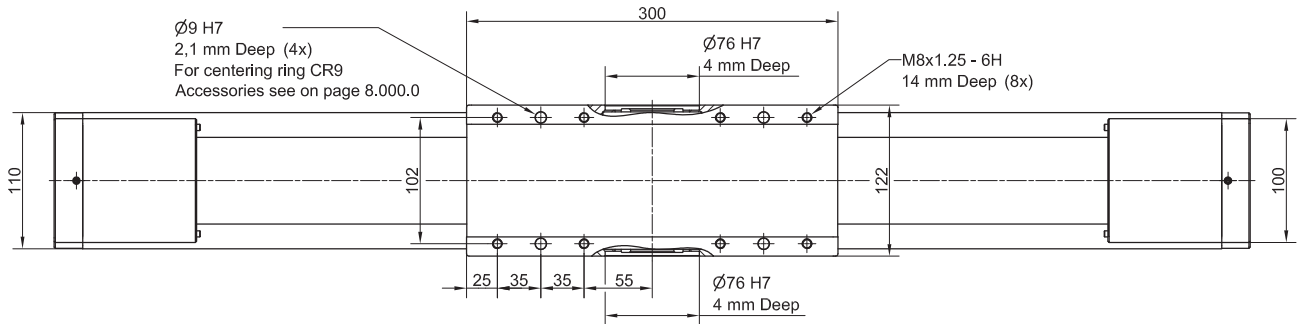
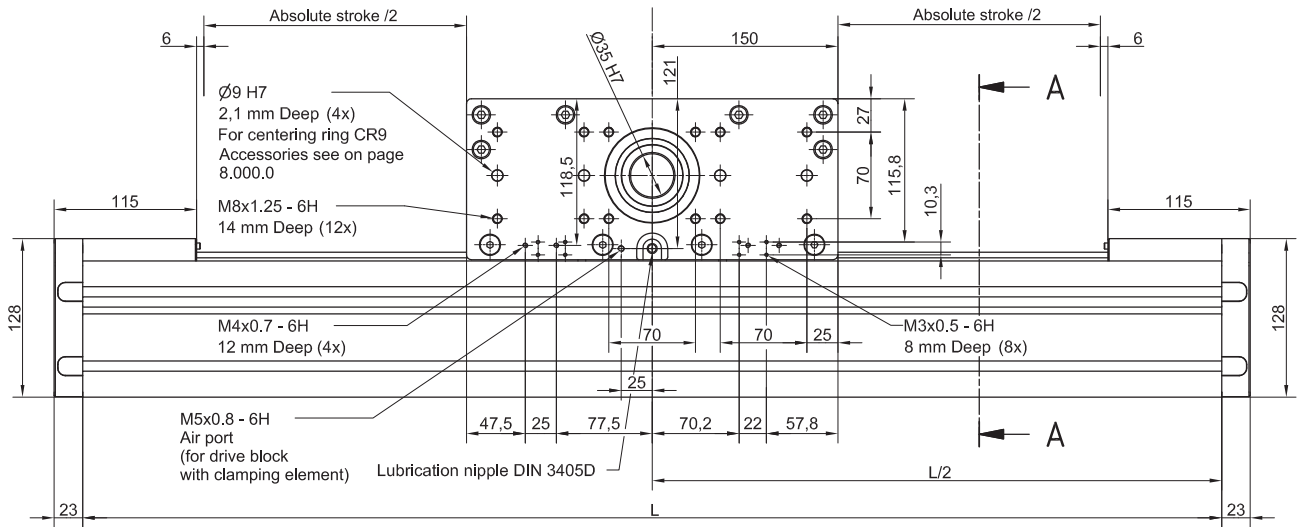

**i** All dimensions in mm; Drawings scales are not equal.

**TYPE 0**

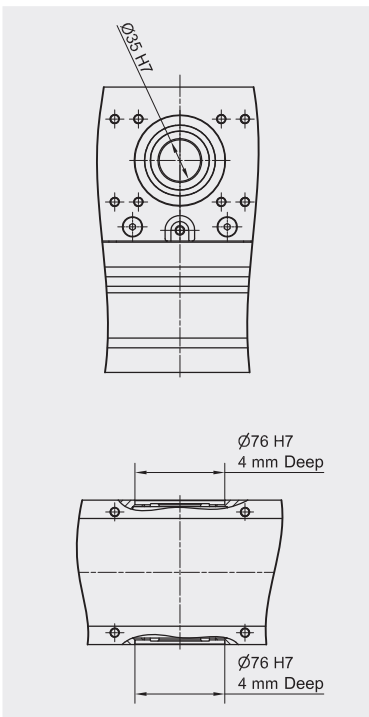

**Drive block with clamping element**

**Clamping by spring-loaded energy**

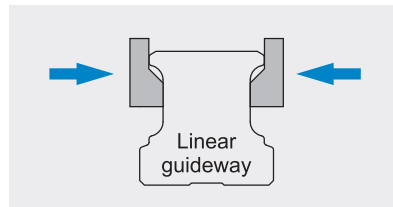

**Air pressure = 0 bar**  
**Holding force = 1400 N**

Holding force is tested on clamping element using a slightly lubricated rail (ISO VG 68).

**Opened by air pressure**

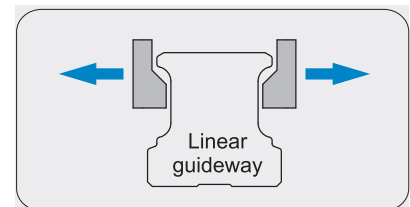

**Opening air pressure = 5,5 - 8 bar**

**i** The air pressure opens clamping pistons. Free movement is allowed.  
Purified and oiled air shall be used (according to ISO 8573-1 Class 4). Recommended filter size is 25 µm.

Linear Unit	Mass of drive block [ kg ]	Mass of linear unit [ kg ]
MTJZ 110	12,9	23,3 + 0,0147 * Stroke [ mm ]

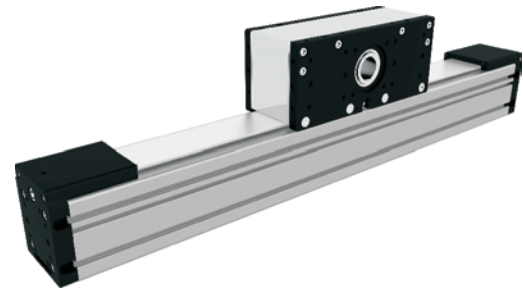
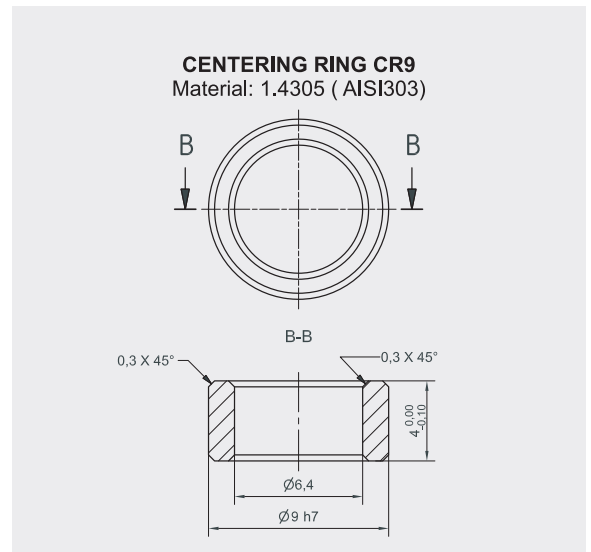
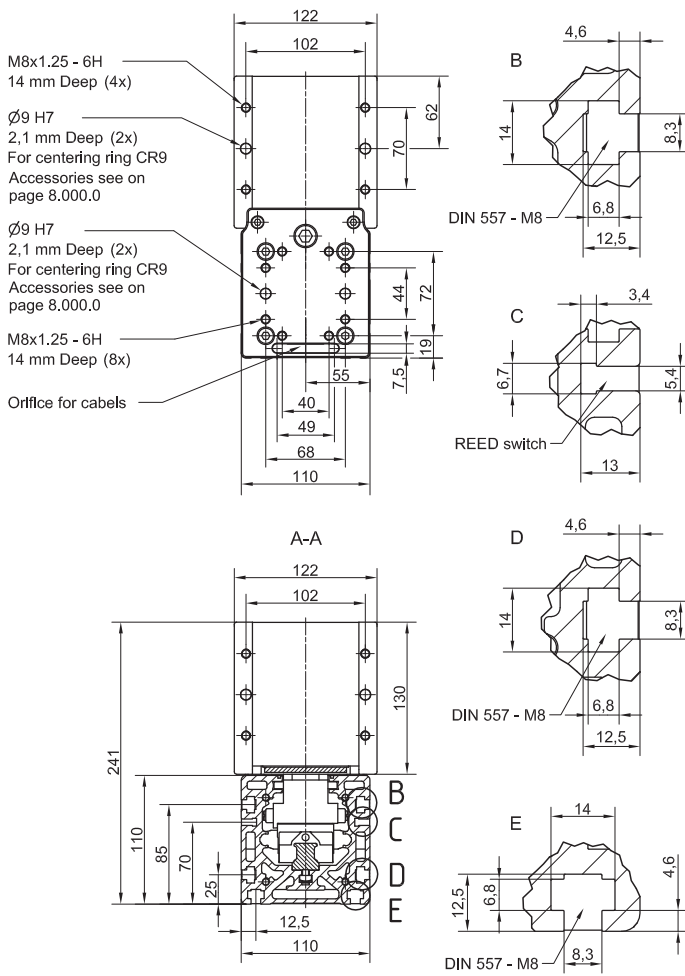

**i** All dimensions in mm; Drawings scales are not equal.

**Defining of the linear unit length**

**$L = \text{Effective stroke} + 2 \times \text{Safety stroke} + 496 \text{ mm}$**

**$L_{\text{total}} = L + 46 \text{ mm}$**

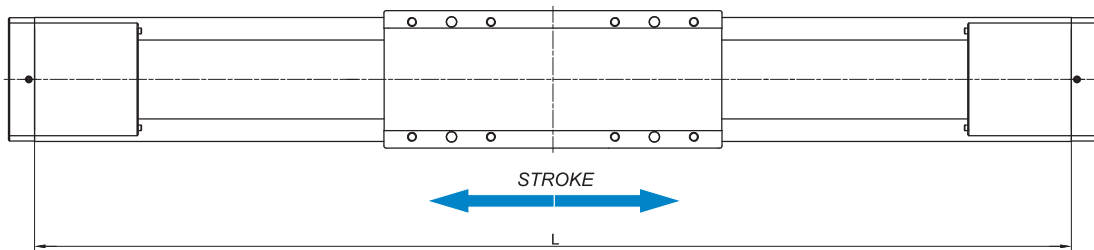

**Multi drive block**

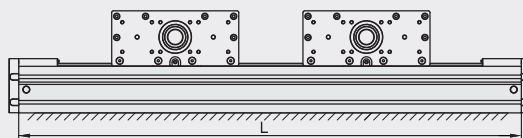

**$L = \text{Effective stroke} + 2 \times \text{Safety stroke} + 300 \times n_b + 196 \text{ mm}$**

$n_b$  - number of drive blocks

**$L_{\text{total}} = L + 46 \text{ mm}$**

