

ROTARY INDEXING TABLE WITH HYBRID DRIVE

TW0150A / TW0200A / TW0300A

MOUNTING INSTRUCTIONS

TD0035A-EN00-0000-00

032019_3.0_EN

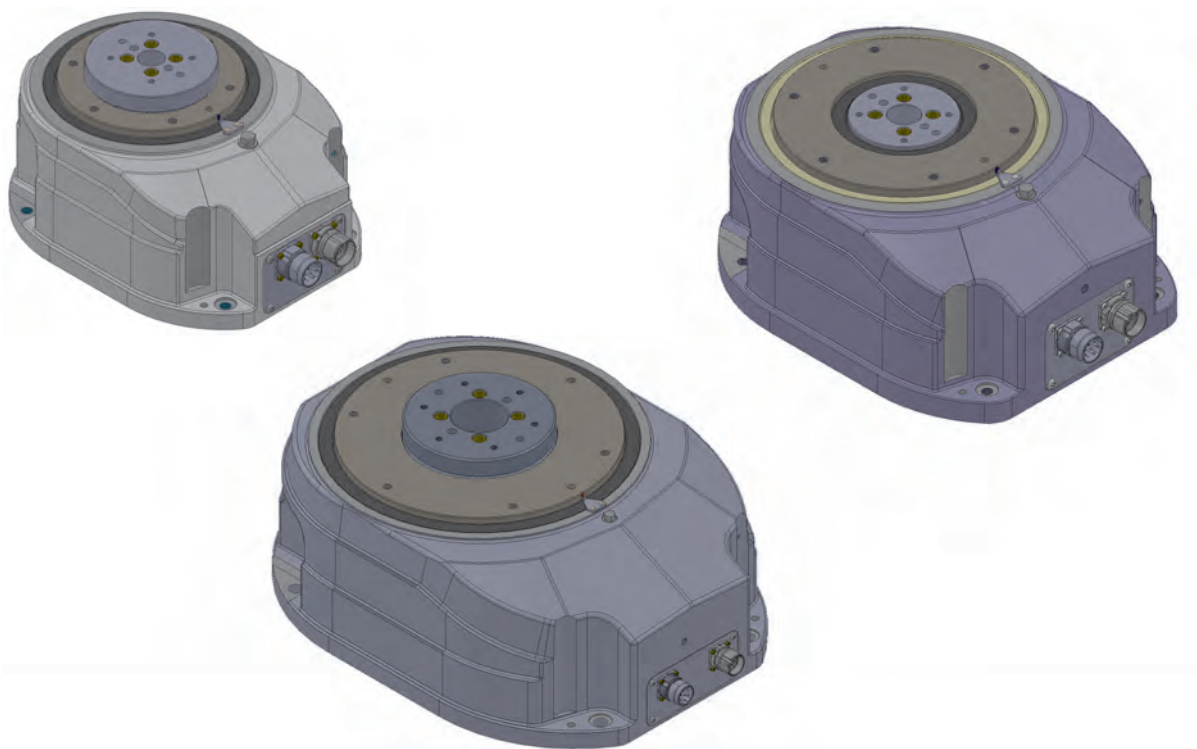

Table of contents

1	Introduction.....	5
1.1	About these mounting instructions.....	5
1.2	Intended use.....	5
1.3	Predictable incorrect application.....	6
1.4	Applicable documents.....	6
1.5	Warranty.....	7
2	Safety.....	8
2.1	Safety messages and hazard categories.....	8
2.2	Hazard symbols.....	9
2.3	Responsibilities of the system integrator and/or operator.....	9
2.4	Qualification of personnel.....	10
3	Product description.....	11
3.1	Overview.....	11
3.2	Function description.....	16
3.3	Nameplate.....	17
3.4	Type code.....	17
3.5	Mounting positions.....	18
3.6	Passage of media.....	19
4	Technical data.....	21
4.1	General.....	21
4.2	Motor.....	21
4.3	Holding brake.....	22
4.4	Encoder.....	22
4.5	Climatic environmental conditions "Operation".....	23
4.6	Climatic environmental conditions "Transportation and Storage".....	23
4.7	Dimensions.....	24
4.8	Load data.....	27
5	Packaging.....	28
5.1	Types of packaging.....	28
5.2	Unpacking the product.....	28
5.3	Verification of the delivery.....	28
6	Transportation.....	29
6.1	Transporting the product.....	29
6.2	Load lifting and handling equipment.....	30
6.3	Fastening the load lifting and handling equipment.....	30



7	Storage	31
	7.1 Storing the product.....	31
8	Mounting	32
	8.1 Prerequisites for mounting.....	32
	8.2 Equipment and tools.....	32
	8.3 Tightening torques and property classes.....	32
	8.4 Displacing the vent screw and the screw plug.....	32
	8.5 Bolting down the product.....	33
	8.6 Mounting additional components.....	35
	8.7 Mounting safety equipment.....	36
9	Electrical connection	37
	9.1 Connection assignment.....	38
10	Controller	40
	10.1 Basic information on control.....	40
	10.2 WEISS GmbH controller/software package (optional).....	40
11	Commissioning	41
	11.1 Prerequisites for commissioning.....	41
	11.2 Performing commissioning.....	41
	11.3 Setting the zero point.....	43
12	Operation	44
	12.1 Basic information on operation.....	44
13	Troubleshooting	45
	13.1 Issue, cause and remedy.....	45
14	Cleaning	47
	14.1 Performing cleaning.....	47
15	Maintenance	49
	15.1 Maintenance plan.....	49
	15.2 Lubricant.....	49
16	Decommissioning	49
	16.1 Decommissioning the product.....	49
17	Dismounting	50
	17.1 Dismounting the product.....	50
18	Disposal	50
	18.1 Disposing of the product.....	50
19	Service and spare parts	51



19.1	Worldwide service.....	51
19.2	Ordering spare parts.....	52

1 Introduction

1.1 About these mounting instructions

These mounting instructions describe the product "Rotary Indexing Table with Hybrid Drive TW0150A / TW0200A / TW0300A" (also referred to as "product" in this document).

These mounting instructions are part of the product.

- You may only use the product if you have fully read and understood these mounting instructions.
- Verify that these mounting instructions are always accessible for any type of work performed on or with the product.
- Pass these mounting instructions as well as all other product-related documents on to all owners of the product.
- If you feel that these mounting instructions contain errors, inconsistencies, ambiguities or other issues, contact the manufacturer prior to using the product.

These mounting instructions are protected by copyright and may only be used as provided for by the corresponding copyright legislation. We reserve the right to modifications.

The manufacturer shall not be liable in any form whatsoever for direct or consequential damage resulting from failure to observe these mounting instructions or from failure to comply with directives, regulations and standards and any other statutory requirements applicable at the installation site of the product.

1.2 Intended use

The product is a partly complete machine pursuant to Directive 2006/42/EU, articles 1g and 2g. The product is only intended to be incorporated into or assembled with other machinery or other partly completed machinery or equipment, thereby forming machinery to which Directive 2006/42/EU applies.

The product may only be used within the limits specified in these mounting instructions and in the applicable documents. The applicable documents are also part of the product.

The machinery must not be put into service until the machinery into which the product has been incorporated has been determined and declared in conformity with the provisions of Directive 2006/42/EU and with all other applicable directives and regulations.

In addition, perform a risk assessment in view of the planned application, according to an approved risk assessment method, and implement the appropriate safety measures, based on the results of the risk assessment. Take into account the consequences of installing or integrating the product into a system or a plant.

When using the product, perform all work and all other activities in conjunction with the product in compliance with the conditions specified in the mounting instructions, in the applicable documents, and on the nameplate, as well as with all directives, standards, and safety regulations applicable at the installation site of the product.

1.3 Predictable incorrect application

Any use of the product beyond the explicitly indicated intended use is an impermissible, incorrect application of the product.

The product must never be used in the following cases, under the following conditions, and for the following purposes:

- Operation in residential environments
- Operation in life-supporting systems
- Operation in potentially explosive atmospheres/hazardous areas
- Operation on ships, in rail vehicles, land craft or in aircraft
- Operation in military facilities
- Operation outside of the specified order data
- Applications involving transportation of persons (fairground rides)

1.4 Applicable documents

In addition to these mounting instructions, the following documents are binding for and apply to any type of use of the product:

- Order data (including, but not limited to, design data, load data, performance data, transportation and storage instructions, information attached to the product and the package, as well as other specifications).
- Documentations of the manufacturers of all products belonging to the scope of delivery (for example, motor, accessories, attachment parts). This includes, among other things:

Type of manual	Type	Manufacturer	Delivery	
			Paper format	Electronic
Mounting instructions	Encoder SEK52-SEL52	SICK STEGMANN GmbH	-	X
Product information	Encoder EQI 1130	DR. JOHANNES HEIDENHAIN GmbH	-	X
Safety data sheet	Lubricant Omala S2 G 220	Shell Deutschland Oil GmbH	-	X
In the case of delivery with WEISS GmbH controller/software package:			Delivery	
			Paper format	Electronic
User manual	"W.A.S. 2 COMPACT" TD0079A-XX00-0000-00	WEISS GmbH	-	X
User manual	"W.A.S. 2 SCALABLE" TD0081A-XX00-0000-00	WEISS GmbH	-	X
Electrical documenta- tion	List of applicable documents, per product (see documents on the CD delivered with the product)	WEISS GmbH	-	X



Introduction

1.5 Warranty

See our website for our General Terms and Conditions at www.weiss-international.com or your purchase order.

2 Safety

2.1 Safety messages and hazard categories

These mounting instructions contain safety messages to alert you to potential hazards and risks. Safety messages in these mounting instructions are highlighted with warning symbols and warning words.

The signal word describes the source of the hazard. The text contains instructions on how to avoid the hazard as well as the consequence resulting from failure to follow the instructions given in the safety message.

Depending on the severity of a hazard, the safety messages are classified according to different hazard categories.



⚠ DANGER

DANGER indicates an immediately hazardous situation, which, if not avoided, will result in death or serious injury.



⚠ WARNING

WARNING indicates a hazardous situation, which, if not avoided, can result in death or serious injury or equipment damage.



⚠ CAUTION

CAUTION indicates a hazardous situation, which, if not avoided, can result in injury or equipment damage.

NOTICE

NOTICE indicates a hazardous situation, which, if not avoided, can result in equipment damage.

In addition to the instructions and safety messages provided in these mounting instructions, you must comply with all directives, standards, and safety regulations applicable at the installation site of the product.

2.2 Hazard symbols

The following symbols are used in these mounting instructions:



This is the general safety alert symbol. It alerts to injury hazards or equipment damage. Comply with all safety instructions in conjunction with this symbol to help avoid possible death, injury, or equipment damage.



This symbol alerts to hazardous electrical voltage. If this symbol is used in a safety message, there is a hazard of electric shock.

Hazard symbols may also be attached to the product.



Hazard of hot surface



Hazard of magnetic field



No access for persons with heart pacemakers or other medical implants

2.3 Responsibilities of the system integrator and/or operator

The system integrator (the person who incorporates the product in a machine pursuant to Directive 2006/42/EU, i.e., for example, the machine builder) and/or the operator must ensure the following:

- The application and use of the product must be limited to the specified intended use.
- In the integration of the product, all functional safety requirements must be met.
- All directives, standards, and safety regulations, including all regulations concerning workplace safety and prevention of accidents, applicable at the installation site of the product must be complied with.
- Any type of work whatsoever on and with the product may only be performed by qualified personnel.
- The product may only be operated when it is in flawless, fully functional condition.
- All safety equipment must operate as required and planned.
- The personal protective equipment for the personnel/operator must be available and must be used.
- The mounting instructions and all applicable documents must always be accessible in their entirety to the personnel at the installation site of the product.
- Safety instructions, labels, and any other information attached to the product must not be removed.
- A complete manual must be available for the machine into which the product is incorporated; this manual must describe all types of work on and with the machine and contain all information relevant with regard to the product.

If the system integrator himself is not in the position to comply with any of these obligations, the system integrator must impose compliance with these obligations on the operator.

2.4 Qualification of personnel

Only trained personnel who have fully read and understood the mounting instructions and all applicable documents for the product may perform work on and with the product.

This trained personnel must have sufficient technical training, knowledge, and experience, and be able to foresee and detect potential hazards that may be caused by using the product.

All trained personnel working on and with the product must be fully familiar with all directives, standards, and safety regulations that must be observed for performing such work.

3 Product description

3.1 Overview

The product consists of the following components:

Product type: TW0150A

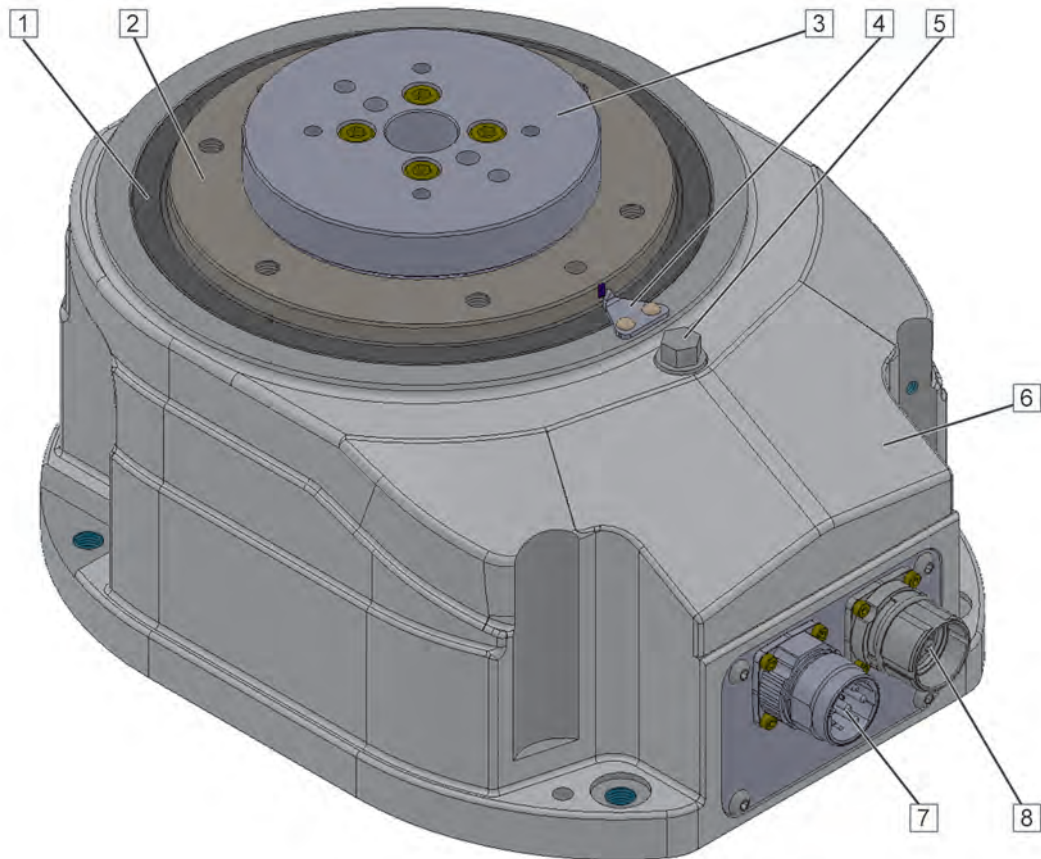

- | | | | |
|---|------------------------|---|--------------------------|
| 1 | Seal | 5 | Vent screw/screw plug |
| 2 | Output flange | 6 | Housing |
| 3 | Stationary center part | 7 | Connection motor cable |
| 4 | Zero point mark | 8 | Connection encoder cable |

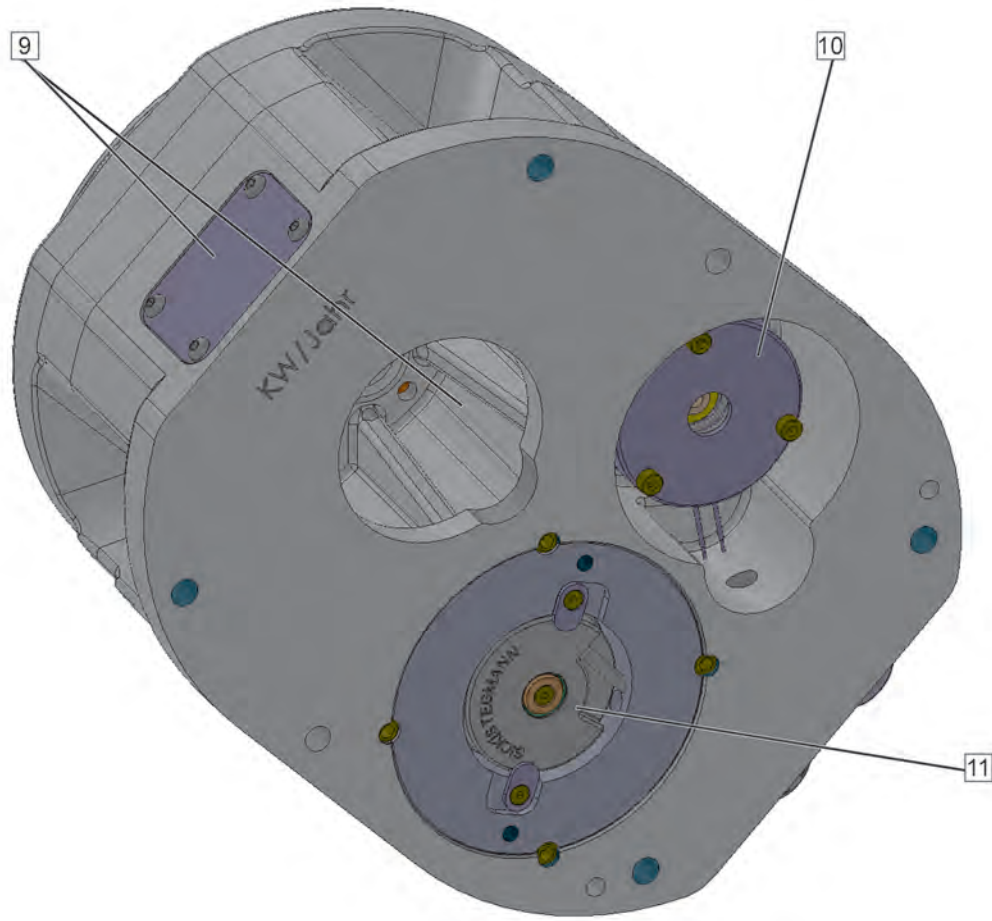

9 Passage of media

10 Holding brake

11 Encoder

Product description

Product type: TW0200A

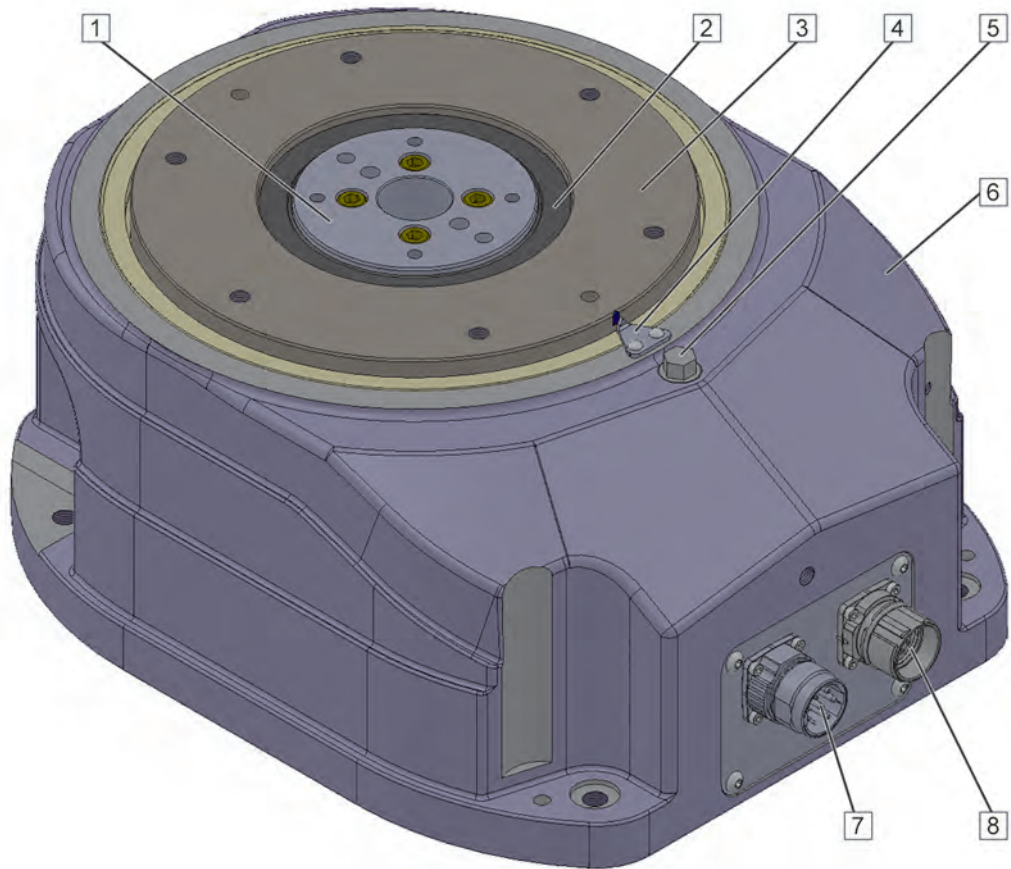

- 1 Stationary center part
- 2 Seal
- 3 Output flange
- 4 Zero point mark

- 5 Vent screw/screw plug
- 6 Housing
- 7 Connection motor cable
- 8 Connection encoder cable

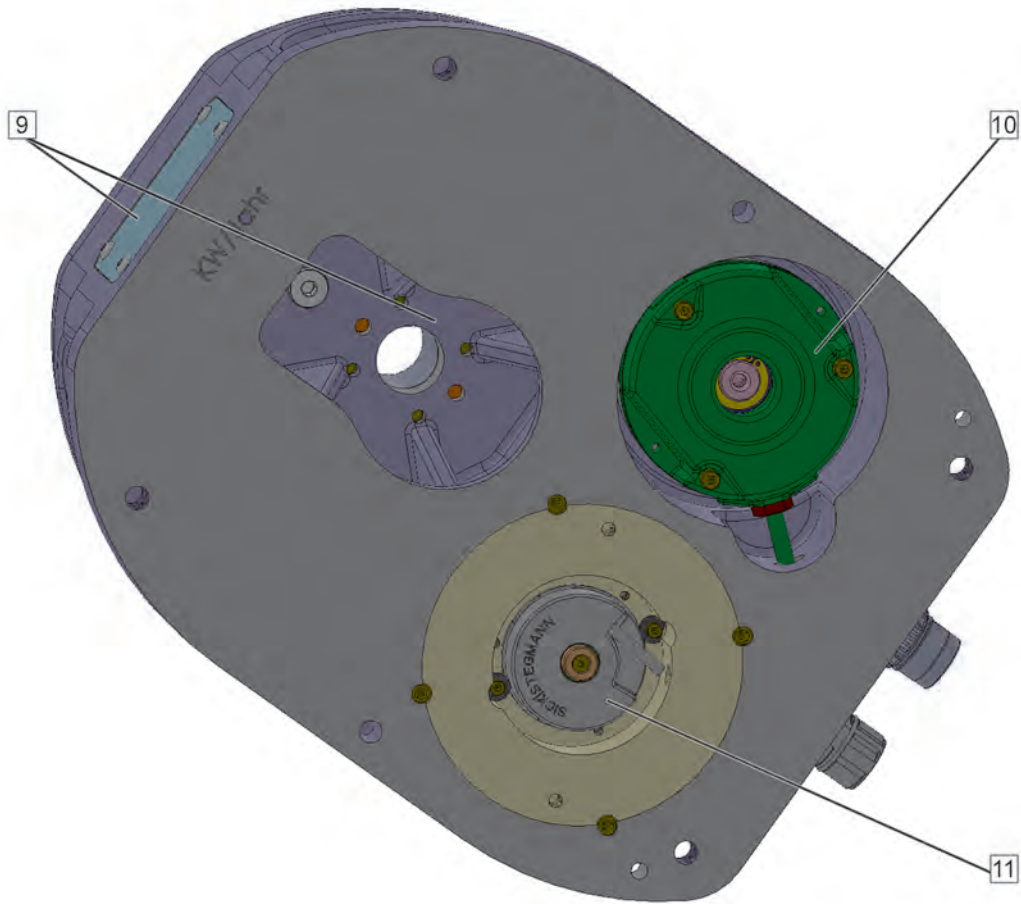

- 9 Passage of media
- 10 Holding brake

- 11 Encoder

Product type: TW0300A

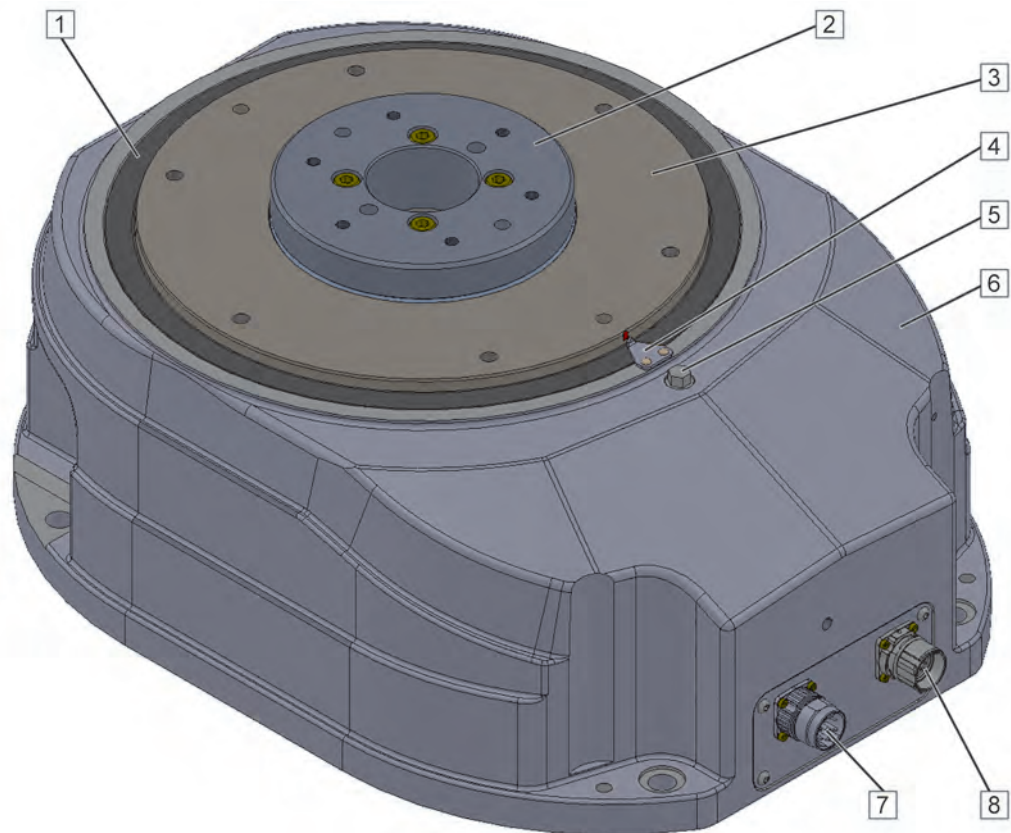

- | | | | |
|---|------------------------|---|--------------------------|
| 1 | Seal | 5 | Vent screw/screw plug |
| 2 | Stationary center part | 6 | Housing |
| 3 | Output flange | 7 | Connection motor cable |
| 4 | Zero point mark | 8 | Connection encoder cable |

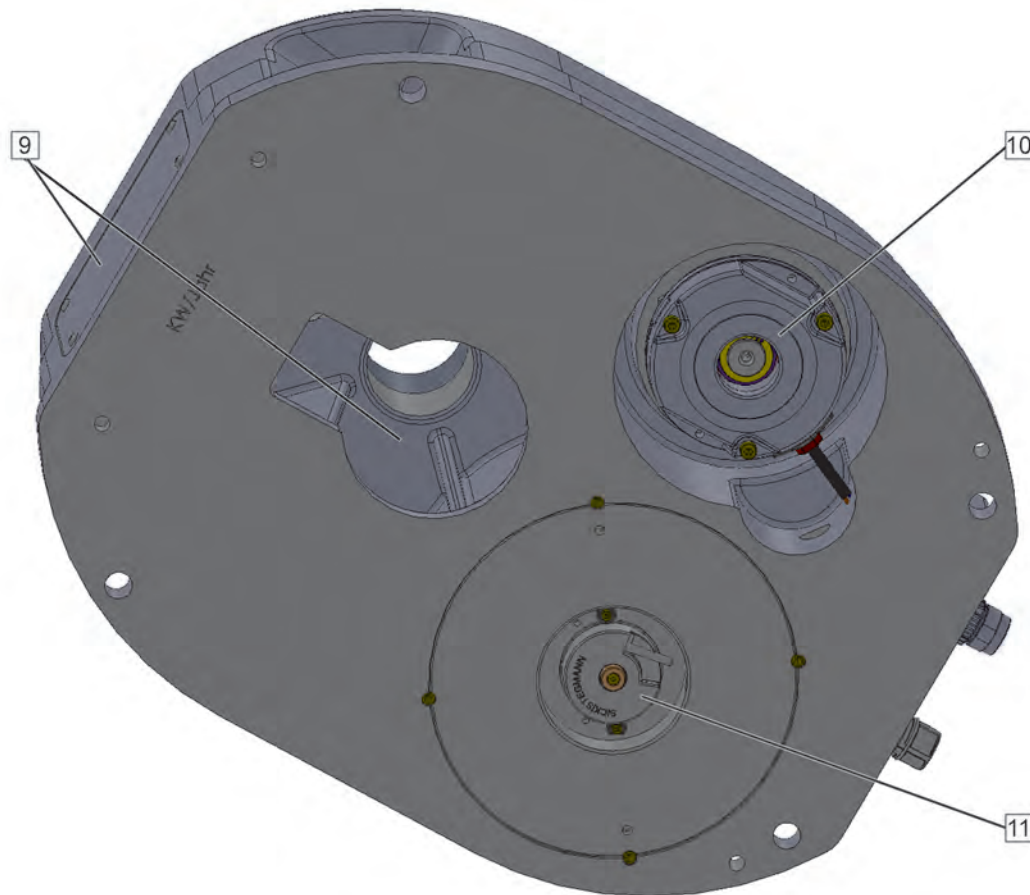

- 9 Passage of media
- 10 Holding brake

- 11 Encoder

3.2 Function description

The motor is controlled by a servo drive according to a programmable motion profile and rotates, accelerates or decelerates the output flange of the product.

The output flange can rotate left, right or alternatingly.

The integrated encoder provides for high positioning accuracy and repeatability.

The optional holding brake holds the output flange in position when it is at a standstill. The braking force is generated by means of springs. The holding brake is released when voltage is applied; the holding brake is applied when the supply voltage is switched off or in the case of power outages.

3.3 Nameplate

The nameplate is attached to the housing of the product; it contains the following information:

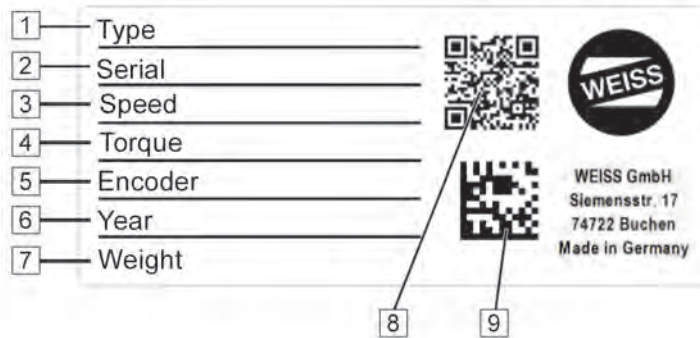

Figure 1: Example of nameplate

- | | | | |
|---|---------------------------|---|---------------------------|
| 1 | Type | 6 | Year of manufacture |
| 2 | Serial number | 7 | Weight |
| 3 | Maximum speed of rotation | 8 | QR code (company website) |
| 4 | Peak torque | 9 | DM code (serial number) |
| 5 | Encoder type | | |

The scope of delivery contains a second nameplate. If the factory-mounted nameplate is covered by attachments, the second nameplate can be attached at a readily visible position of the product or machine for identification of the product.

3.4 Type code

Structure of the type code:

Type	Size	Encoder	Connector type	Holding brake
TW	0150A 0200A 0300A	A (Hiperface) B (EnDat 2.1)	A	B (with holding brake)

3.5 Mounting positions

NOTICE

OIL LOSS OR DRY RUN DUE TO INCORRECT MOUNTING POSITION

Failure to follow these instructions can result in equipment damage.

- Verify that you only use the standard mounting positions approved in these mounting instructions.

Permissible standard mounting positions

The product may only be mounted as shown below.

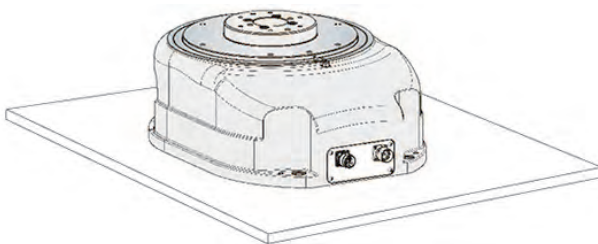

Normal/MP 1

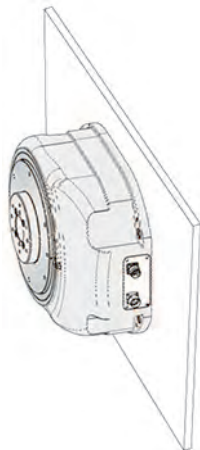

Axis of rotation vertical/MP 2

Special mounting positions

The following special mounting positions require explicit approval of the manufacturer for the product.



Upside down/MP 3

3.6 Passage of media

Product type: TW0150A

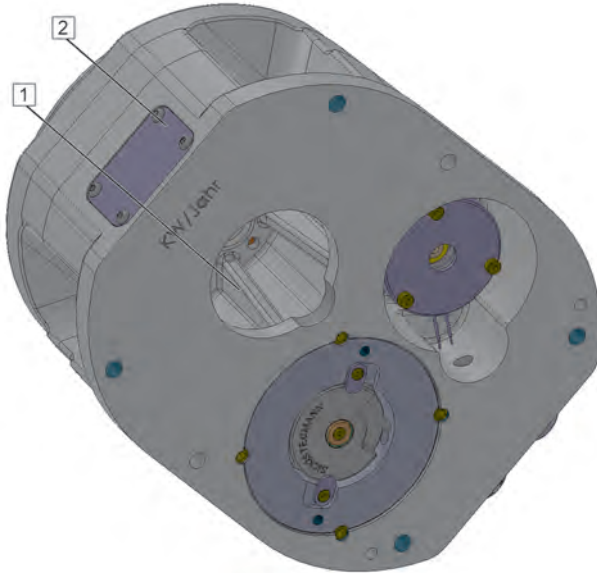

The large center hole [1] and the opening in the housing [2] can be used for the passage of media.

Product type: TW0200A

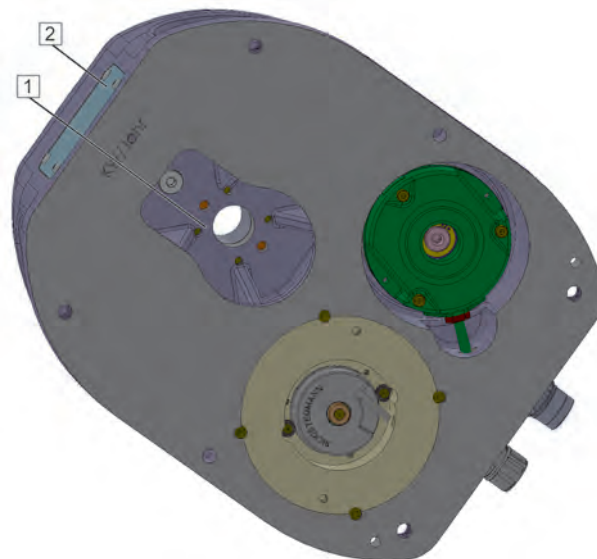

The large center hole [1] and the opening in the housing [2] can be used for the passage of media.

Product type: TW0300A

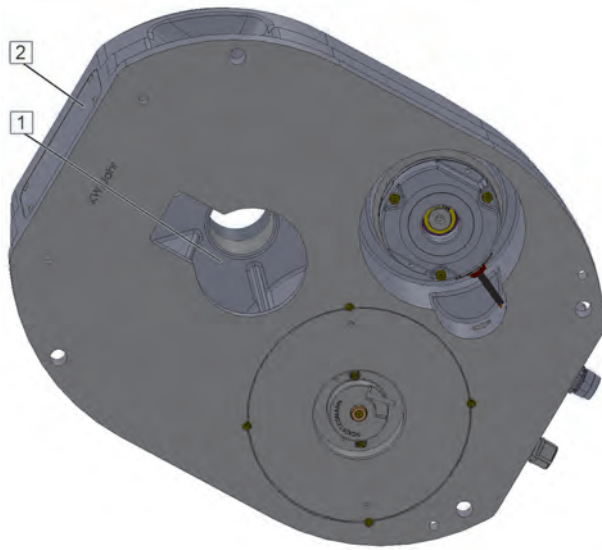

The large center hole [1] and the opening in the housing [2] can be used for the passage of media.

4 Technical data

4.1 General

Characteristic	Unit	Value		
		TW0150A	TW0200A	TW0300A
Direction of rotation	-	Programmable		
Indexing accuracy	arcsec	± 65	± 55	± 45
Maximum axial runout output flange	mm	± 0.01		
Maximum radial runout output flange	mm	± 0.01		
Maximum diameter of rotary plate	mm	750	1000	1500
Weight	kg	27	40	106
Total weight including packaging	kg	See bill of delivery		
Sound pressure	dB(A)	< 70		
Lubricant	-	Shell Omala S2 G 220		
Lubricant volume	ml	120	240	360

4.2 Motor

Characteristic	Unit	Value		
		TW0150A	TW0200A	TW0300A
Number of pole pairs	-	10	11	11
DC bus voltage	V _{DC}	320	320/560	560
Voltage range	V _{AC rms}	200 ... 480	200 ... 480	400 ... 480
Test voltage	V _{AC}	2000	2000	2000
Voltage constant	mV/min	95	226	309
Nominal speed of rotation	min ⁻¹	2260	930	1230
Maximum speed of rotation at 230 V**	min ⁻¹	1860	690	-
Maximum speed of rotation at 400 V**	min ⁻¹	-	1440	1110
Nominal torque	Nm	2.3	13.1	33.1
Peak torque	Nm	10.8	25.5	115
Torque constant	Nm/A _{rms}	1.499	3.547	4.867
Nominal current	A	3.8	1.5	6.8
Peak current	A	7.5	7.4	27.2
Winding cross section	mm ²	0.2463	0.28274	1.135
Stator resistance at 20°C*	Ohm	6.368	9.42	1.922

Characteristic	Unit	Value		
Stator inductance*	Henry	0.01684	0.024	0.0156
Moment of inertia	kgm ²	0.0003	0.0007	0.0055
Temperature monitoring	-	Triple PTC		
Limit temperature	°C	120		
Output				
Gear ratio	i	9	10	11
Nominal speed of rotation	min ⁻¹	251.1	93	111.8
Maximum speed of rotation	min ⁻¹	206	69	111
Nominal torque	Nm	20.7	131	364.1
Peak torque	Nm	97.2	255	1265
Friction torque	Nm	5	15	20
Moment of inertia	kgm ²	0.0054	0.031	0.28

* Measured between phase and phase.

** Depends on application

4.3 Holding brake

Characteristic	Unit	Value		
		TW0150A	TW0200A	TW0300A
Nominal current	A	0.52	1.05	1.25
Braking torque	Nm	1.5	7.5	15
Time delay for applying	s	0.25	0.07	0.07
Time delay for releasing	s	0.12	0.07	0.07
Maximum backlash when holding brake is applied	mm	± 0.12	± 0.12	± 0.12

4.4 Encoder

See the documentation of the manufacturer for the technical data of the additional encoder, applicable documents.

Type	System accuracy	Interface
SEL52 (for product type TW0150A)	± 65"	Hiperface
SEL52 (for product type TW0200A)	± 55"	Hiperface
SEL52 (for product type TW0300A)	± 45"	Hiperface

Type	System accuracy	Interface
EQI 1130 (for product type TW0150A)	± 65"	EnDat 2.1
EQI 1130 (for product type TW0200A)	± 55"	EnDat 2.1
EQI 1130 (for product type TW0300A)	± 45"	EnDat 2.1

4.5 Climatic environmental conditions "Operation"

Characteristic	Unit	Value
Ambient temperature	°C	+15 ... +45
Relative humidity, non-condensing	%	+5 ... +95
Maximum surface temperature	°C	100
Maximum installation altitude above mean sea level	m	1000

4.6 Climatic environmental conditions "Transportation and Storage"

Characteristic	Unit	Value
Ambient temperature	°C	+5 ... +55
Relative humidity, non-condensing	%	+5 ... +95
Maximum storage duration of the mechanical components	-	see chapter 7

4.7 Dimensions

Product type: TW0150A

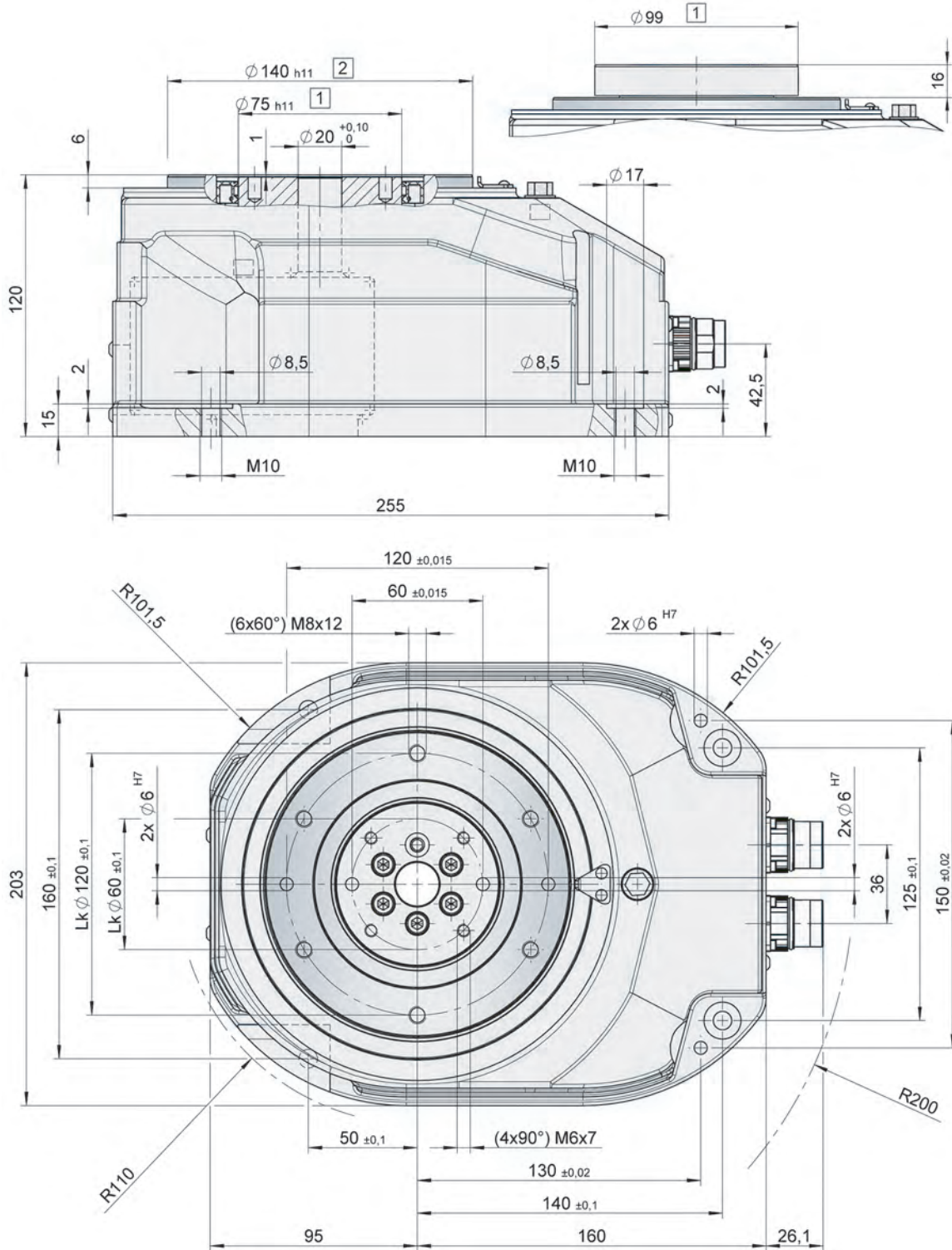

Figure 2: Lengths and diameters in mm

1 Stationary center part

2 Output flange

Product type: TW0300A

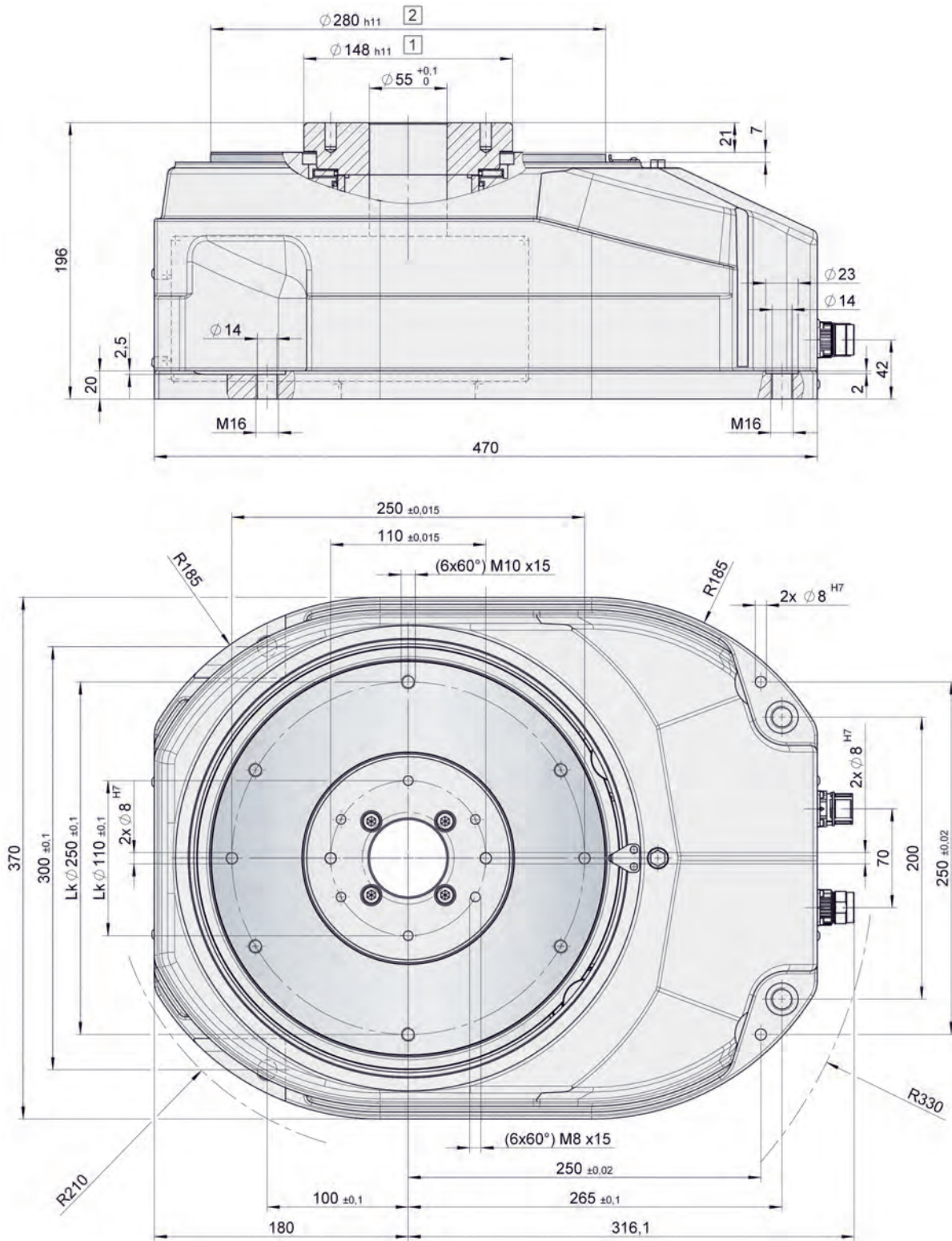

Figure 4: Lengths and diameters in mm

1 Stationary center part

2 Output flange

4.8 Load data

Load data for stationary center part

Characteristic	Unit	Value		
		TW0150A	TW0200A	TW0300A
Permissible torque	Nm	140	145	800
Permissible moment of tilt	Nm	200	300	1800
Permissible axial force	N	3500	5000	18000
Permissible radial force	N	2500	4000	6000

Load data for output flange

Characteristic	Unit	Value		
		TW0150A	TW0200A	TW0300A
Maximum acceleration torque	Nm	60	180	450
Nominal torque	Nm	30	90	225
Permissible static moment of tilt	Nm	500	700	2250
Permissible static axial force	N	5500	7500	15000
Permissible static radial force	N	6000	8000	13000

5 Packaging

5.1 Types of packaging



Packaging in Europe

The product is placed on corrugated cardboard and oil paper, screwed onto a palette, packaged in special cardboard and covered with oil paper.

Packaging for air and sea freight

The product is factory-packaged in Corpac-co-ex-VCI film, screwed onto a palette, packed into a special cardboard box with wooden struts and the interstices are filled with foam plastic material.

5.2 Unpacking the product

1. Do not remove the packaging until immediately prior to mounting.
2. Dispose of the packaging material in compliance with all directives, standards, and safety regulations applicable at the installation site.

5.3 Verification of the delivery

- Check the delivery for completeness and transportation damage upon reception.
- In the case of damage, reject the delivery or accept it only conditionally.
- Document the damage in the transportation documents/bill of delivery (any damage detected must be immediately reported to the forwarding agent and confirmed by the forwarding agent).
- Take photographs of the damage.
- Report the damage to WEISS GmbH.

6 Transportation



▲ WARNING

FALLING, TOPPLING, OR LOWERING LOADS

Insufficiently rated load lifting and handling equipment may break. Transportation vehicles, lifting gear, chains, belts, and other equipment not rated for the product may fail or tilt.

Failure to follow these instructions can result in death, serious injury, and equipment damage.

- Only use transportation vehicles, lifting gear, chains, belts, and other lifting and handling equipment that comply with all applicable regulations and that are rated for the weight of the product including packaging.
- Verify that there are no persons in the danger zone.
- Verify that the product is properly secured against falling and toppling.

6.1 Transporting the product

Packages fastened to a pallet can be transported with a fork lift truck, a pallet jack or similar transportation means. Verify that the transportation means used is suitable and approved for the weight and the dimensions of the package.



1. Place the forks below the pallet.
2. Verify that the pallet with the package fully rests on the forks.
3. Fasten the pallet with the package using additional straps if the center of gravity is not in the center of the pallet.

6.2 Load lifting and handling equipment



Use properly rated load lifting and handling equipment and hoisting belts/hoisting equipment for transporting the product. Eyebolts must not be used as load lifting and handling equipment.

6.3 Fastening the load lifting and handling equipment



⚠ WARNING

FALLING, TOPPLING, OR LOWERING LOADS

Insufficiently rated load lifting and handling equipment may break. Transportation vehicles, lifting gear, chains, belts, and other equipment not rated for the product may fail or tilt.

Failure to follow these instructions can result in death, serious injury, and equipment damage.

- Only use transportation vehicles, lifting gear, chains, belts, and other lifting and handling equipment that comply with all applicable regulations and that are rated for the weight of the product including packaging.
- Verify that there are no persons in the danger zone.
- Verify that the product is properly secured against falling and toppling.

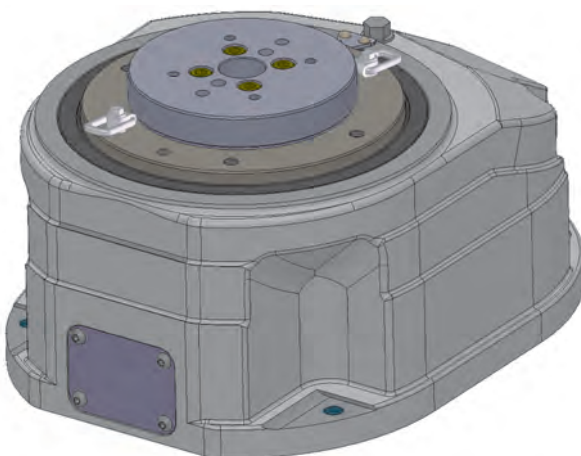

1. Use properly rated load lifting and handling equipment and hoisting belts for transporting the product.
2. Screw the load lifting and handling equipment (M8) into the outer threads of the output flange.
3. Fasten the hoisting belts or the hoisting equipment to the eyelets of the load lifting or load handling equipment.

7 Storage

7.1 Storing the product

NOTICE

INCORRECT STORAGE

Failure to follow these instructions can result in equipment damage.

- Verify compliance with all conditions specified in these mounting instructions and all applicable documents when storing the product.

The mechanical components of the product can be stored for a period of up to two years.

Conditions for the specified maximum storage duration:

- Storage in original packaging
- Compliance with all specified storage conditions
- Storage in suitable closed, dry, dust-free room, protected against direct sunlight
- No contact with corrosive media
- Corrosion protection intact

The electrical components have a different maximum storage duration (see documentations of the manufacturers).

If the maximum storage duration has been exceeded, you must contact the manufacturer prior to commissioning the product. This also applies if the machine in which the product has been incorporated has not been operated for a period of time exceeding the maximum storage durations specified for the mechanical and electrical components.

If you plan to store the product for a period of time exceeding the maximum permissible storage duration specified for the mechanical components, you must uninstall the electrical components prior to storing the product. The electrical components must be stored according to the specifications of the manufacturers (see documentations of the manufacturers).

If the product is to be stored for a period of more than three months, the product must first be preserved. If the factory-applied anti-corrosion agent is no longer intact, you must request preservation instructions from the manufacturer.

8 Mounting

8.1 Prerequisites for mounting

NOTICE

DAMAGE TO SHAFT SEALING RINGS

Failure to follow these instructions can result in equipment damage.

- Avoid any contact of the sealing lips of the shaft sealing rings with the solvent.

Prior to mounting, verify that the dimensions of the installation site and construction conditions meet the requirements and the dimensions specified in these mounting instructions and the applicable documents.

- Verify that the supporting base is level and rigid.
- Verify that the supporting structure at the installation site has a sufficient structural strength to carry the weight of the product and of all loads.

8.2 Equipment and tools

The following is required for mounting:

- Set of hex keys
- Torque wrench
- Cotter pin punch (for mounting the parallel pins)

8.3 Tightening torques and property classes

Only use screws with the property class shown in the following table unless a different property class is explicitly specified for a screw connection.

Use the tightening torque shown in the following table unless a different tightening torque is explicitly specified for a screw connection.

Property class of screws	10.9 (coefficient of friction $\mu_{tot.}$ 0.12)			
Thread	M8	M10	M14	M16
Tightening torque	33 Nm	65 Nm	181 Nm	277 Nm

8.4 Displacing the vent screw and the screw plug

NOTICE

OIL LOSS OR DRY RUN DUE TO INCORRECT MOUNTING POSITION

Failure to follow these instructions can result in equipment damage.

- Verify that you only use the standard mounting positions approved in these mounting instructions.

Mounting

1. The vent screw and the screw plug are factory-mounted according to the mounting position you specify in your order. If you want to modify the mounting position, you must displace the vent screw and the screw plug.

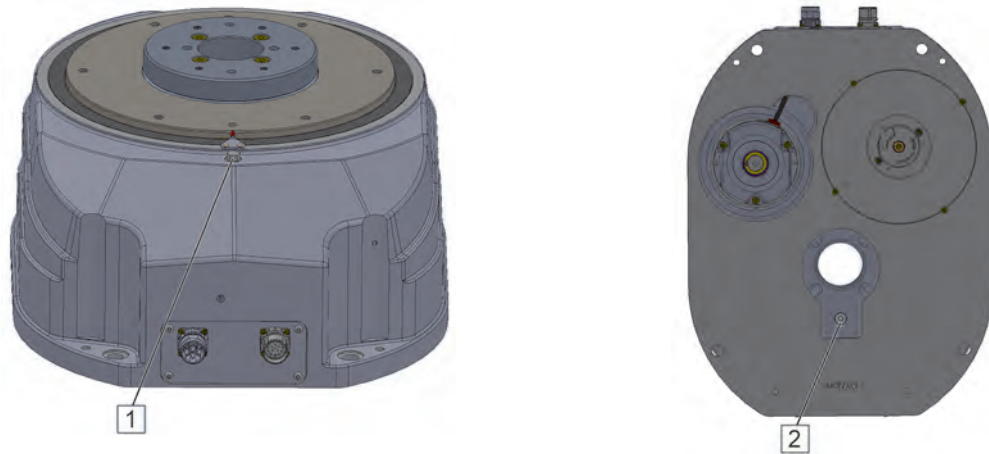

	Normal/MP 1	Axis of rotation vertical/MP 2	Upside down/MP 3
Mounting position			
Position vent screw	1	1	2
Position screw plug	2	2	1

8.5 Bolting down the product



WARNING

FALLING, TOPPLING, OR LOWERING LOADS

Insufficiently rated load lifting and handling equipment may break. Transportation vehicles, lifting gear, chains, belts, and other equipment not rated for the product may fail or tilt.

Failure to follow these instructions can result in death, serious injury, and equipment damage.

- Only use transportation vehicles, lifting gear, chains, belts, and other lifting and handling equipment that comply with all applicable regulations and that are rated for the weight of the product including packaging.
- Verify that there are no persons in the danger zone.
- Verify that the product is properly secured against falling and toppling.

**▲ WARNING****IMPROPERLY FASTENED PARTS**

Failure to follow these instructions can result in death, serious injury, and equipment damage.

- Verify that the supporting structure and/or the frame and/or the mounting surface for fastening the product are sufficiently rated to withstand all static and dynamic loads and forces during operation.
- Verify that the fastening parts comply with the specifications indicated and that they are sufficiently rated for all load conditions during operation.

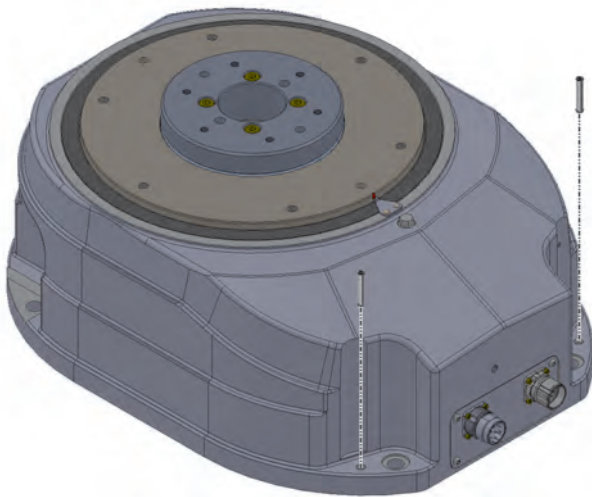

Use screws with the property class specified to mount the product. When determining the length of the screws, take into account the loads and forces acting in your application as well as the characteristics of the supporting structure to which the product is mounted.

1. Place the product at the mounting site in compliance with the transportation instructions and align it according to the pin holes and the holes.
2. Center the product with the parallel pins via the pin holes and then drive in the first parallel pin by one third.
3. Hand-tighten the product to the mounting surface with four screws.
4. Drive the two parallel pins into the pin holes.
5. Tighten the four screws.
6. Remove all transportation aids and equipment as well as all mounting tools from the product.

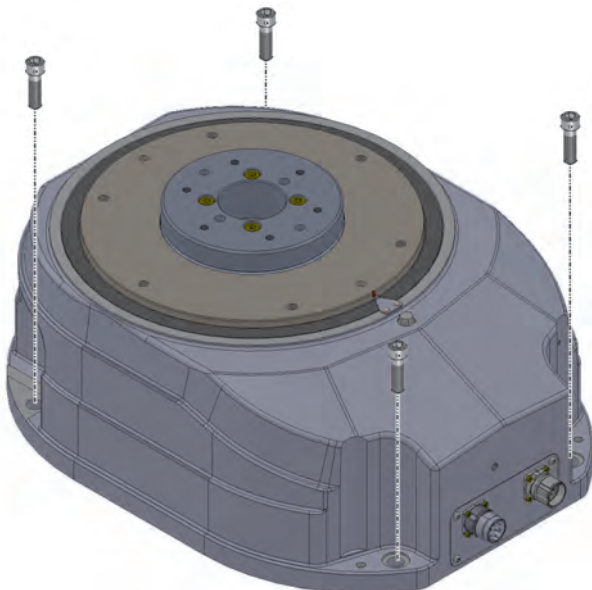

8.6 Mounting additional components



WARNING

IMPROPERLY FASTENED PARTS

Failure to follow these instructions can result in death, serious injury, and equipment damage.

- Verify that the supporting structure and/or the frame and/or the mounting surface for fastening the product are sufficiently rated to withstand all static and dynamic loads and forces during operation.
- Verify that the fastening parts comply with the specifications indicated and that they are sufficiently rated for all load conditions during operation.



WARNING

INCORRECT USE AND/OR FASTENING OF ADDITIONAL COMPONENTS

Failure to follow these instructions can result in death, serious injury, and equipment damage.

- Only mount components to the output flange that are approved by the manufacturer.
- Only use existing holes in the output flange for mounting additional components to the output flange.
- Do not drill holes into the output flange.
- Do not attach further parts to the output flange (for example, by means of welding) to mount additional components.

Mounting the rotary plate

A rotary plate may only be mounted via the fit holes or threads.

If there is a centering collar at the stationary center part of the product, this centering collar must not be used to fasten an additional indexing plate.

For this reason, the center hole of a rotary plate must be approx. 2 mm larger than the centering collar. When determining the length of the screws, take into account the loads and forces acting in your application as well as the characteristics of the supporting structure to which the product is mounted.

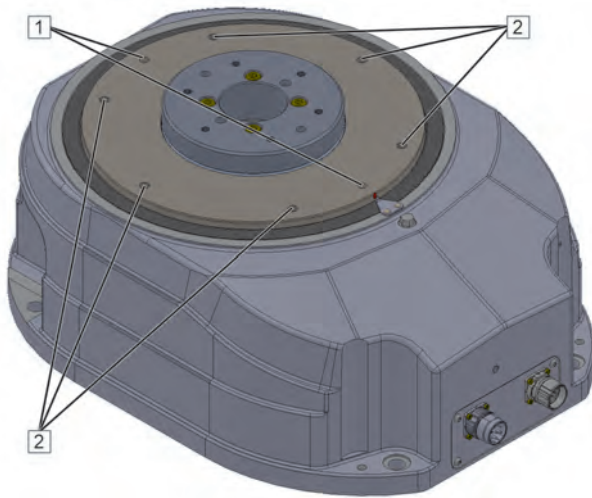

1. Fit the rotary plate.
2. Center the parallel pins and then drive in the first parallel pin [1] by one third of the way.
3. Screw the rotary plate to the output flange with six screws [2].
4. Fully drive in the first and the second parallel pin [1].
5. Tighten the screws [2] cross-wise with a tightening torque suitable for the application.
6. Remove all transportation aids and equipment as well as all mounting tools from the product.
7. Set the zero point, [see chapter 11.3](#).

8.7 Mounting safety equipment

The product is a partly complete machine pursuant to Directive 2006/42/EU and intended to be incorporated into or assembled with other machinery. The requirements concerning functional safety and the corresponding safety equipment result from the risk analysis and the risk assessment for the final machine or plant.

Selection, mounting, installation, commissioning, operation and maintenance of the safety equipment must be performed by the system integrator (the person who incorporates the product in a machine pursuant to Directive 2006/42/EU, i.e., for example, the machine builder) and/or the operator.

The product requires at least the following safety equipment:

- Emergency Stop system as per IEC 60204-1 / ISO 13850
- Lockable main switch to interrupt the complete power supply to all electrical components of the product

9 Electrical connection



⚠ DANGER

ELECTRIC SHOCK CAUSED BY LIVE PARTS

Failure to follow these instructions will result in death or serious injury.

- Disconnect the mains supply voltage before performing the work and ensure that it cannot be switched on.
- Verify that no hazards can be caused by electrically conductive objects.
- Verify that all cables for the power supply are disconnected from power.
- Verify that all electrical connections are made to the specifications in the wiring diagrams.



⚠ WARNING

UNANTICIPATED MOVEMENT

Interchanging the motor connections inverts the direction of rotation of the motor.

Failure to follow these instructions can result in death, serious injury, and equipment damage.

- Verify correct wiring and connection of all electrical connections.



⚠ CAUTION

IMPROPERLY INSTALLED CABLES

Failure to follow these instructions can result in injury or equipment damage.

- Verify that the cables are correctly routed.
- Verify compliance with the bend radius specifications for the electrical lines.
- Only use cables with the correct cross sections.
- Verify that the electrical cables are correctly connected to the terminals.

The following components must be connected for the motor:

- Lockable main switch
- Suitable Emergency Stop equipment (as per IEC 60204-1 / EN ISO 13850)

Connector type



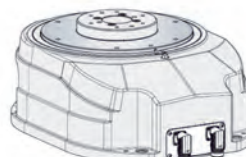

Straight connector





Angled connector, 90° downwards

9.1 Connection assignment

Motor

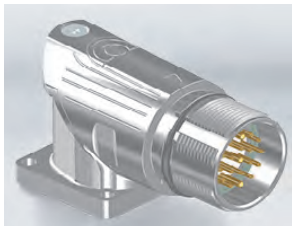

Motor connector with male thread M23	Isolation piece 8-pin E	Pin assignment		
		Pin	Designation	Function
		1	U	Motor phase U
		4	V	Motor phase V
		3	W	Motor phase W
			PE	Protective ground conductor
		A	T+	Temperature sensor +
		B	T-	Temperature sensor -
		C	B+	Holding brake +
		D	B-	Holding brake -

Encoder "Hiperface"

Encoder connector with male thread M23	Isolation piece 12-pin E	Pin assignment		
		Pin	Designation	Function
		1	---	---
		2	---	---
		3	COS+	COS+
		4	REFCOS	REFCOS
		5	SIN+	SIN+
		6	REFSIN	REFSIN
		7	DATA-	Data inverted
		8	DATA+	Data
		9	---	---
		10	---	---
		11	GND	GND
		12	+7 ... 12 V	Encoder + 7 ... 12 V

Electrical connection

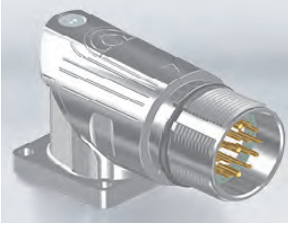
Encoder "EnDat 2.1"

Encoder connector with male thread M23	Isolation piece 17-pin E	Pin assignment		
		Pin	Designation	Function
		1	Sense 5 V	Sense + 5 V
		2	---	---
		3	---	---
		4	Sense GND	Sense GND
		5	---	---
		6	---	---
		7	5 V	Encoder + 5 V
		8	CLOCK+	Clock
		9	CLOCK-	Clock inverted
		10	GND	GND
		11	---	---
		12	B+	Sine
		13	B-	Sine inverted
		14	DATA+	Data
		15	A+	Cosine
		16	A-	Cosine inverted
17	DATA-	Data inverted		

10 Controller

10.1 Basic information on control



▲ WARNING

LOSS OF CONTROL

Failure to follow these instructions can result in death, serious injury, and equipment damage.

- Consider all potential failure modes of all control paths in your control concept.
- Implement means and measures for all critical functions to achieve a safe state if a control path fails (for example, emergency stop, overtravel of positions, power outage, and restart).
- Implement separate or redundant control paths for all critical functions.
- If the control system of the machine comprises communication links, consider the consequences of unanticipated transmission delays or failures of the link and implement appropriate measures.
- Subject each machine in which the product described in these mounting instructions is used to a comprehensive and thorough commissioning test before operating the machine.

10.2 WEISS GmbH controller/software package (optional)

WEISS GmbH offers a controller/software package for controlling the product.

If this option is used, you must follow all instructions in the corresponding documentations. The documentations can be found on the CD shipped with the product in the controller/software package.

11 Commissioning

11.1 Prerequisites for commissioning

The following requirements must be met before the product may be commissioned:

- The product is properly mounted.
- The electrical equipment for the power supply of the motor and the holding brake is mounted correctly.
- All cables are properly routed and connected.
- All electrical connections have been made properly.
- All parts of the system are properly grounded in compliance with directives, regulations, and standards.
- All safety equipment and EMERGENCY-STOP circuits are operational.
- The drive is not damaged and not blocked.
- All environmental conditions are respected.
- All protective covers are properly mounted.
- All tools, equipment, and other objects have been removed from the zone of operation of the product.
- All hazards are excluded.

Prior to commissioning, perform a test for each prerequisite mentioned and verify compliance with all information and specifications contained in these mounting instructions, in all applicable documents, and in all applicable directives, regulations, and standards.

11.2 Performing commissioning



WARNING

UNANTICIPATED MOVEMENT

Incorrect connections or external influences on electrical equipment can cause unanticipated movements.

Failure to follow these instructions can result in death, serious injury, and equipment damage.

- Verify correct wiring.
- Verify that there are no persons or obstacles in the danger zone of the product before starting the product.
- Perform initial test movements without loads and without other processing units.
- Verify that all safety equipment and EMERGENCY STOP circuits are activated prior to commissioning.



⚠ WARNING

UNINTENDED EQUIPMENT OPERATION

Incorrect or unsuitable parameter values or settings can cause unintended movements, trigger signals, and compromise functional safety.

Failure to follow these instructions can result in death, serious injury, and equipment damage.

- Verify that parameter values and settings can only be modified by authorized personnel who fully understand each and every effect of such a modification.
- Verify that all parameter values and settings are correct by performing a test run.



⚠ WARNING

HOT SURFACES

The temperature of the motor and the holding brake can exceed 100 °C during operation.

Failure to follow these instructions can result in death, serious injury, and equipment damage.

- Avoid unprotected contact with hot surfaces.
- Do not allow flammable or heat-sensitive objects in the vicinity of hot surfaces.
- Before performing work on the motor or the holding brake, verify that you wait for a sufficient period of time to allow such parts to cool down to a temperature that allows for safe contact.

Power on the power supply to the product via the main switch.

Check the following points during commissioning:

- Operating state, potential error conditions, and protective equipment
 - During commissioning, perform tests for all operating states and error conditions. In doing so, verify that all protective equipment operates as planned and required.
- Correct operation of the motor
 - There are no overloads.
 - There are no unusual fluctuations in the speed of rotation. Immediately stop the product in the case of overloads or unusual fluctuations in the speed of rotation and verify correct mounting.
- Noise emission
 - Excessive noise emission can be an indication of incorrect mounting, for example, an uneven ground that causes mechanical stress at the output flange. Immediately stop the product in the case of high noise emission and verify correct mounting.
- Heat
 - Verify that the heat dissipation is sufficient and that the specified climatic environmental conditions are respected by performing a test run under maximum load conditions.

If the product and/or the machine into which the product is incorporated is temporarily decommissioned, it must be recommissioned. For recommissioning, the same prerequisites must be met as for initial commissioning.

Perform the same tests for each recommissioning of the product as for initial commissioning.

11.3 Setting the zero point



⚠ WARNING

INVALID ZERO POINT

Failure to follow these instructions can result in death, serious injury, and equipment damage.

- Verify that a valid zero point is correctly set immediately after the following types of work are performed: mounting/dismounting of rotary plate as well as dismounting or replacement of the servo drive/controller and the battery of the controller.

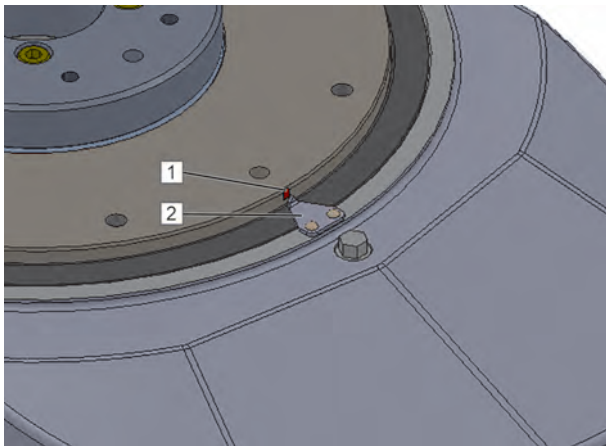

For setting the zero point, zero point marks are provided at the housing [2] and at the output flange [1] of the product.

It is also possible to select a different zero point. If a different zero point is used, the corresponding zero point marks must be added to the product (like the factory-provided zero point marks).

1. Switch on the main switch.
2. Rotate the output flange via the controller (for example, W.A.S. 2) in operating mode Jog until the two zero point marks are facing.
3. Set the zero point in the controller and save it.

12 Operation

12.1 Basic information on operation



⚠ WARNING

UNINTENDED EQUIPMENT OPERATION

Incorrect or unsuitable parameter values or settings can cause unintended movements, trigger signals, and compromise functional safety.

Failure to follow these instructions can result in death, serious injury, and equipment damage.

- Verify that parameter values and settings can only be modified by authorized personnel who fully understand each and every effect of such a modification.
- Verify that all parameter values and settings are correct by performing a test run.



⚠ WARNING

UNANTICIPATED MOVEMENT OF THE OUTPUT FLANGE

If the holding brake becomes inoperative, the output flange can move even if the motor is at a standstill.

Failure to follow these instructions can result in death, serious injury, and equipment damage.

- Block or safeguard the output flange in such a way that a movement of the output flange is safely prevented before starting work on the output flange.

The product is a partly complete machine pursuant to Directive 2006/42/EU and intended to be incorporated into or assembled with other machinery. The information required for operation results from the functionality of the machine or system into which the product is incorporated and from the application implemented with it.

The instructions for the safe operation of the final machine or system must be provided by the system integrator (the person who incorporates the product in a machine pursuant to Directive 2006/42/EU) and/or the operator in the form of a manual with operating instructions, [see chapter 2.3](#).

These operating instructions must be a complete manual which describes all work on and with the product and which contains all information relevant to the product. The system integrator and/or operator must ensure compliance of the operating instructions with all applicable directives, regulations, and standards.

13 Troubleshooting

13.1 Issue, cause and remedy



DANGER

ELECTRIC SHOCK CAUSED BY LIVE PARTS

Failure to follow these instructions will result in death or serious injury.

- Disconnect the mains supply voltage before performing the work and ensure that it cannot be switched on.
- Verify that no hazards can be caused by electrically conductive objects.
- Verify that all cables for the power supply are disconnected from power.
- Verify that all electrical connections are made to the specifications in the wiring diagrams.



WARNING

MOVING PARTS

Failure to follow these instructions can result in death, serious injury, and equipment damage.

- Verify that the zone of operation of the moving parts of the product/machine is safeguarded.



WARNING

HOT SURFACES

The temperature of the motor and the holding brake can exceed 100 °C during operation.

Failure to follow these instructions can result in death, serious injury, and equipment damage.

- Avoid unprotected contact with hot surfaces.
- Do not allow flammable or heat-sensitive objects in the vicinity of hot surfaces.
- Before performing work on the motor or the holding brake, verify that you wait for a sufficient period of time to allow such parts to cool down to a temperature that allows for safe contact.



Issue	Cause	Remedy
Output flange does not rotate or does not reach the next position	Bearing is inoperable	▪ Contact the Weiss Service Department, see chapter 19.1
The defined position is no longer valid	The encoder is defective	
The product generates unusual noise	Bearing is inoperable	

14 Cleaning

14.1 Performing cleaning



DANGER

ELECTRIC SHOCK CAUSED BY LIVE PARTS

Failure to follow these instructions will result in death or serious injury.

- Disconnect the mains supply voltage before performing the work and ensure that it cannot be switched on.
- Verify that no hazards can be caused by electrically conductive objects.
- Verify that all cables for the power supply are disconnected from power.
- Verify that all electrical connections are made to the specifications in the wiring diagrams.



WARNING

UNANTICIPATED MOVEMENT OF THE OUTPUT FLANGE

If the holding brake becomes inoperative, the output flange can move even if the motor is at a standstill.

Failure to follow these instructions can result in death, serious injury, and equipment damage.

- Block or safeguard the output flange in such a way that a movement of the output flange is safely prevented before starting work on the output flange.



WARNING

MISSING PROTECTIVE EQUIPMENT

Failure to follow these instructions can result in death, serious injury, and equipment damage.

- Immediately reinstall protective equipment that you may have removed to perform maintenance work after having completed the maintenance work and verify the effectiveness of the protective equipment.



WARNING

MOVING PARTS

Failure to follow these instructions can result in death, serious injury, and equipment damage.

- Verify that the zone of operation of the moving parts of the product/machine is safeguarded.



▲ WARNING

HOT SURFACES

The temperature of the motor and the holding brake can exceed 100 °C during operation.

Failure to follow these instructions can result in death, serious injury, and equipment damage.

- Avoid unprotected contact with hot surfaces.
- Do not allow flammable or heat-sensitive objects in the vicinity of hot surfaces.
- Before performing work on the motor or the holding brake, verify that you wait for a sufficient period of time to allow such parts to cool down to a temperature that allows for safe contact.

For cleaning of electrical components and additional components, respect the instructions in the documentations of the manufacturer; refer to the applicable documents.

Use the following cleaning agents for cleaning the product:

Component	Cleaning agents
Housing	Neutral, mildly alkaline
Output flange	

1. Remove fine impurities and dust with a dry, lint-free cloth.
2. Use a wet cloth and a neutral, mildly alkaline cleaning agent to remove stains on the housing and/or on the output flange.
3. Dry the cleaned areas.
4. Remove all equipment from the product.
5. Restore the readiness for operation of the product.

15 Maintenance

15.1 Maintenance plan

When	Activity
At least every six months or if required	<ul style="list-style-type: none"> ▪ Clean all surfaces of the product, see chapter 14.1
	<ul style="list-style-type: none"> ▪ Verify all screw connections of the product for correct tightening torque
	<ul style="list-style-type: none"> ▪ Verify correct connection of all plug connections

15.2 Lubricant

The product features lifetime lubrication. Refer to the documentation of the manufacturer for information on the lubricants used; see applicable documents.

16 Decommissioning

16.1 Decommissioning the product

1. Switch off the product and secure it against unintended switching on.
2. Remove all workpieces and all other objects not belonging to the product from the product.
3. In the case of recommissioning, follow the instructions described, [see chapter 11](#).

17 Dismounting

17.1 Dismounting the product



⚠ WARNING

FALLING, TOPPLING, OR LOWERING LOADS

Insufficiently rated load lifting and handling equipment may break. Transportation vehicles, lifting gear, chains, belts, and other equipment not rated for the product may fail or tilt.

Failure to follow these instructions can result in death, serious injury, and equipment damage.

- Only use transportation vehicles, lifting gear, chains, belts, and other lifting and handling equipment that comply with all applicable regulations and that are rated for the weight of the product including packaging.
- Verify that there are no persons in the danger zone.
- Verify that the product is properly secured against falling and toppling.

1. Switch off the supply voltage.
2. Dismount the product (reverse sequence of steps), [see chapter 8](#).

18 Disposal

18.1 Disposing of the product

Dispose of the product in compliance with all applicable directives, standards, and safety regulations.

Environmental protection

Dispose of lubricants, greases, residue of cleaning agents and other non-recyclable materials according to the applicable directives, standards, and safety regulations.



19 Service and spare parts

19.1 Worldwide service

If you need the assistance of our service departments, please provide the following information:

- Serial number of the product (see nameplate)
- Description of the problem
- Time of occurrence and circumstances of the problem
- Suspected cause

GERMANY

WEISS GmbH
Siemensstraße 17
74722 Buchen/Odenw.
Phone +49-6281-5208-5999
Fax +49-6281-5208-99
E-mail info@weiss-gmbh.de

SWITZERLAND

WEISS Schweiz GmbH
Friedhofstraße 7
2540 Grenchen
Phone +41-32-6536010
Fax +41-32-6536011
E-Mail info@weiss-gmbh.ch

NETHERLANDS

WEISS Nederland
Kruisstraat 4
7573 GJ Oldenzaal
Phone +31-541-853524
E-mail info@weiss-gmbh.nl

POLAND

WEISS Poland Sp. z o. o.
ul. Wielicka 250
30-663 Kraków
Phone +48-12-281-23-62
Fax +48-12-281-23-63
E-Mail info@weiss-poland.com

ITALY

WEISS Italia S.r.l.
Via dell'Arcoveggio 49/5
40129 Bologna
Phone +39-51-0474967
E-mail info@weiss-italia.it

USA | CANADA

WEISS North America, Inc.
3860 Ben Hur Avenue, Suite 3
Willoughby, OH 44094
Phone +1-888 WEISSNA (888-934-7762)
Fax +1-440-269-8036
E-mail info@weissna.com

SPAIN

WEISS España
Tecnología en máquinas especiales, S.L.
Avda. Juan Carlos I, N°13, 3ªA „Torre Garena“
28806 Alcalá de Henares (Madrid)
Phone +34-91-830-06-86
Fax +34-91-830-06-87
E-mail info@weiss-gmbh.es

UNITED KINGDOM

WEISS UK Ltd.
Meridian House
Winsford Ind Estate
Winsford
Cheshire
CW7 3QG
Phone +44-1606-8605-67
E-mail info@weiss.uk.com

INDIA

WEISS Automation Solutions India Pvt. Ltd.
Office No. 101
Navale IT Park
Survey No. 51/2A/2
Nahre, Pune -411041
Phone +91-20-2469-9810
E-mail info@weiss-india.com

BRASIL

WEISS Brasil Ltda
Rod. BR 280 KM 43, n.º 501 - 3.º Pavimento,
Poço Grande, Guaramirim - SC
Caixa Postal n.º 57 - Cep 89270 - 000
Phone +55-47-99914-9681 ou
+55-47-99971-1554
E-mail info@weiss-brasil.com

ASIA

WEISS Asia
Automation and Components Pte Ltd
18 Boon Lay Way
#07-112
TradeHub 21
Singapore 609966
Phone +65-6570-3274
Fax +65-6684-6757
E-mail info@weiss-asia.com

KOREA

WEISS Korea Co., Ltd.
213-ho, 448, Aenggogae-ro, Namdong-gu,
Incheon, Republic of Korea (21697)
Phone +82-32-228-5208
Fax +82-32-228-5209
E-mail sales@weiss-korea.com

CHINA

WEISS AUTOMATION TECHNOLOGY
(SHANGHAI) CO., LTD.
中国区总部/ Head Office in China
上海/ Shanghai
地址: 上海市嘉定区马陆镇思诚路
1250号8号楼
ADD: Building 8, No.1250 Sicheng Rd., Jiading
District
Phone +86-21-6076-7688 (总机 / Call Center)
Fax +86-21-6076-7699
E-mail info@weiss-china.com

19.2 Ordering spare parts



WARNING

UNSUITABLE SPARE PARTS AND ACCESSORIES

Failure to follow these instructions can result in death, serious injury, and equipment damage.

- Only use spare parts and accessories which are approved by the manufacturer.

Please provide the following information when ordering spare parts:

- Serial number of the product (see nameplate)
- Part number of the spare part according to spare parts list
- Quantity of spare parts required



**INSPIRING PEOPLE
GREAT SOLUTIONS**

WEISS GmbH

Siemensstraße 17 74722 Buchen
Telefon 06281 5208-0 Telefax 06281 5208-99
info@weiss-international.com
www.weiss-international.com